

SCAG[®]

POWER EQUIPMENT

MODEL STT-31BSG



THIS MANUAL CONTAINS THE OPERATING INSTRUCTIONS AND SAFETY INFORMATION FOR YOUR SCAG MOWER. READING THIS MANUAL CAN PROVIDE YOU WITH ASSISTANCE IN MAINTENANCE AND ADJUSTMENT PROCEDURES TO KEEP YOUR MOWER PERFORMING TO MAXIMUM EFFICIENCY. THE SPECIFIC MODELS THAT THIS BOOK COVERS ARE CONTAINED ON THE INSIDE COVER. BEFORE OPERATING YOUR MACHINE, PLEASE READ ALL THE INFORMATION ENCLOSED.

OPERATOR'S MANUAL



WARNING:

FAILURE TO FOLLOW SAFE OPERATING PRACTICES MAY RESULT IN SERIOUS INJURY.

- * Keep all shields in place, especially the grass discharge chute.
- * Before performing any maintenance or service, stop the machine and remove the spark plug wires and ignition key.
- * If a mechanism becomes clogged, stop the engine before cleaning.
- * Keep hands, feet and clothing away from power-driven parts.
- * Read this manual completely as well as other manuals that came with your mower.
- * Keep others off the tractor (only one person at a time)

REMEMBER - YOUR MOWER IS ONLY AS SAFE AS THE OPERATOR!

Hazard control and accident prevention are dependent upon the awareness, concern, prudence, and proper training of the personnel involved in the operation, transport, maintenance, and storage of the equipment.

This manual covers the operating instructions
and illustrated parts list for:

STT-31BSG	with a serial number of 8580001 to 8589999
SMST-61A	with a serial number of 8600001 to 8609999
SMST-72A	with a serial number of 8610001 to 8619999

Always use the entire serial number listed on the serial number tag when referring to this product.



TABLE OF CONTENTS

SUBJECT	PAGE
Section 1 - General Information	
1.1 Introduction	1
1.2 Directional Reference	1
1.3 Servicing the Engine and Drive Train Components	1
Section 2 - Safety Information	
Symbols	2-3
2.1 Introduction	4
2.2 Signal Words	4
2.3 Before Operation Considerations	4
2.4 Operation Considerations	5
2.5 Maintenance Considerations	6
2.6 Safety and Instructional Decals	7
Section 3 - Specifications	8-9
Section 4 - Operating Instructions	
4.1 Controls and Instrument Identification	10
4.2 Safety Interlock System	11
4.3 Initial Run-In Procedures	12
4.4 Starting the Engine	12
4.5 Ground Travel and Steering	12
4.6 Engaging the Deck Drive	13
4.7 Hillside Operation	14
4.8 Parking the Mower	14
4.9 After Operation	14
4.10 Removing Clogged Material	15
4.11 Moving Mower with Engine Stopped	15
4.12 Recommendations for Mowing	15
4.13 Adjusting Cutting Height	16
Section 5 - Troubleshooting Cutting Conditions.....	17-19

TABLE OF CONTENTS (CONT'D)

SUBJECT	PAGE
Section 6 - Adjustments	
6.1 Parking Brake Adjustment	20
6.2 Travel Adjustments	20
6.3 Throttle Control and Choke Adjustments	22
6.4 Belt Adjustment	22
6.5 Belt Alignment	22
6.6 Cutter Deck Adjustments	23
 Section 7 - Maintenance	
7.1 Maintenance Chart	26
7.2 Lubrication Fitting Points	27
7.3 Hydraulic System	29
7.4 Engine Oil	30
7.5 Engine Fuel System	31
7.6 Engine Air Cleaner	31
7.7 Battery	31
7.8 Drive Belts	33
7.9 Cutter Blades	33
7.10 Tires	34
7.11 Cutter Deck Gearbox	35
7.12 Cooling System	35
7.13 Body, Deck, Hopper and Upholstery	36
 Section 8 - Illustrated Parts List	
SMST 61" Adv., 72" Adv. Cutter Decks	38-39
Cutter Deck Controls	40-41
Sheet Metal Components	42-43
Deck Drive Components	44-45
Radiator, Coolers & Engine Brackets.....	46-47
Brake & Steering Components.....	48-49
Fuel & Hydraulic System	50-51
Electrical System	52-53
Hydraulic Pump Assembly - BDP-21L	54-55
Wire Harness, STT-31BSG	56
Replacement Decals	57-58

GENERAL INFORMATION

1.1 INTRODUCTION

Your mower was built to the highest standards in the industry. However, the prolonged life and maximum efficiency of your mower depends on you following the operating, maintenance and adjustment instructions in this manual.

If additional information or service is needed, contact your Scag Power Equipment Dealer.

We encourage you to contact your dealer for repairs. All Scag dealers are informed of the latest methods to service this equipment and provide prompt and efficient service in the field or at their service shop. They carry a full line of Scag service parts.

USE OF OTHER THAN ORIGINAL SCAG REPLACEMENT PARTS WILL VOID THE WARRANTY.

When ordering parts, always give the model and serial number of your tractor. The serial number plate is located where shown in Figures 1-1.

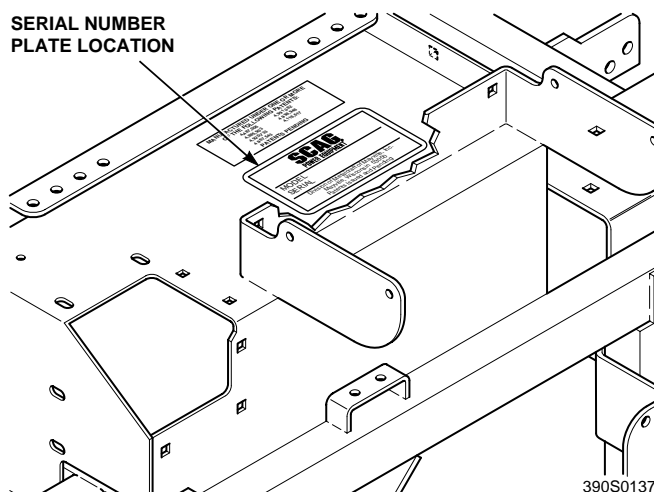

Figure 1-1 Tractor Serial Number Plate Location

For pictorial clarity, some illustrations and figures in this manual may show shields, guards or plates open or removed. Under no circumstances should your mower be operated without these devices in place.

All information is based upon product information available at the time of approval for printing. Scag Power Equipment reserves the right to make changes at any time without notice and without incurring any obligation.









1.2 DIRECTION REFERENCE











The “Right” and “Left”, “Front” and “Rear” of the machine are referenced from the operator’s right and left when seated in the normal operating position and facing the forward travel direction.

1.3 SERVICING THE ENGINE AND DRIVE TRAIN COMPONENTS

The detail servicing and repair of the engine, hydraulic pumps and gearboxes are not covered in this manual; only routine maintenance and general service instructions are provided. For service of these components during the limited warranty period, it is important to contact your Scag dealer or find a local authorized servicing agent of the component manufacturer. Any unauthorized work done on these components during the warranty period may void your warranty.

ISO Symbols		CE Mark
--------------------	--	----------------

SYMBOL	DESCRIPTION	SYMBOL	DESCRIPTION
	Choke		Transmission
	Parking Brake	 <small>48071S</small>	Spinning Blade
	On/Start		Spring Tension on Idler
	Off/Stop		Oil
		Falling Hazard	

SYMBOL	DESCRIPTION	SYMBOL	DESCRIPTION
	Fast		Slow
	Continuously Variable - Linear		Cutting Element - Basic symbol
	Pinch Point		Cutting Element - Engage
	Hourmeter/Elapsed Operating Hours		Cutting Element - Disengage
	Thown Object Hazard Keep Bystanders Away		Read Operator's Manual

SAFETY INFORMATION

2.1 INTRODUCTION

Your mower is only as safe as the operator. Carelessness or operator error may result in serious bodily injury or death. Hazard control and accident prevention are dependent upon the awareness, concern, prudence, and proper training of the personnel involved in the operation, transport, maintenance and storage of the equipment. Make sure every operator is properly trained and thoroughly familiar with all of the controls before operating the mower.

READ THIS OPERATOR’S MANUAL BEFORE ATTEMPTING TO START YOUR MOWER.

A replacement manual is available from your authorized Scag Service Dealer or by contacting Scag Power Equipment, Service Department at P.O. Box 152, Mayville, WI 53050 or contact us via the Internet at www.scag.com. Use the contact form to make your request. Please indicate the complete model and serial number of your Scag product when requesting replacement manuals.

2.2 SIGNAL WORDS



This symbol means “**Attention! Become Alert! Your Safety is Involved!**” The symbol is used with the following signal words to attract your attention to safety messages found on the decals on the machine and throughout this manual. The message that follows the symbol contains important information about safety. To avoid injury and possible death, carefully read the message! Be sure to fully understand the causes of possible injury or death.

Signal Word:

The signal word is a distinctive word found on the safety decals on the machine and throughout this manual that alerts the viewer to the existence and relative degree of the hazard.

DANGER:

The signal word “DANGER” denotes that an extremely hazardous situation exists on or near the machine that could result in high probability of death or irreparable injury if proper precautions are not taken.

WARNING:

The signal word “WARNING” denotes that a hazard exists on or near the machine that can result in injury or death if proper precautions are not taken.

CAUTION:

The signal word “CAUTION” is a reminder of safety practices on or near the machine that could result in personal injury if proper precautions are not taken.

Your safety and the safety of others depends significantly upon your knowledge and understanding of all correct operating practices and procedures of this machine.

2.3 BEFORE OPERATION CONSIDERATIONS

1. **NEVER** allow children to operate this riding mower. Do not allow adults to operate this machine without proper instructions.
2. **DO NOT** mow when children and/or others are present.
3. Clear the area to be mowed of objects that could be picked up and thrown by the cutter blades.
4. **DO NOT** carry passengers.

Section 2

2.3 BEFORE OPERATION CONSIDERATIONS (CONT'D)

5. **DO NOT** wear loose fitting clothing that could get tangled in moving parts. Do not operate the machine wearing shorts; always wear adequate protective clothing including long pants. Wearing safety glasses, safety shoes and a helmet is advisable and is required by some local ordinances and insurance regulations.
6. Operator hearing protection is recommended, particularly for continuous operation of the mower. Wear suitable hearing protection. Prolonged exposure to loud noise can cause hearing impairment or hearing loss.
7. Keep the machine and attachments in good operating condition. Keep all shields and safety devices in place. If a shield, safety device or decal is defective or damaged, repair or replace it before operating the machine.

WARNING:

This machine is equipped with an interlock system intended to protect the operator and others from injury. This is accomplished by preventing the engine from starting unless the deck drive is disengaged, the parking brake is on, the steering control levers are in the neutral position and the operator is in the seat. The system shuts off the engine if the operator leaves the seat with the deck drive engaged and/or the steering control levers are not in the neutral position and the parking brake is not engaged. Never operate equipment with the interlock system disconnected or malfunctioning.

8. Be sure the interlock switches are functioning correctly.
9. Fuel is flammable; handle it with care. Fill the fuel tank outdoors. Never fill it indoors. Use a funnel or spout to prevent spillage. Clean up any spillage before starting the engine.

10. **DO NOT** add fuel to a running or hot engine. Allow the engine to cool for several minutes before adding fuel.
11. Keep flammable objects (cigarettes, matches, etc.), open flames and sparks away from the fuel tank and fuel container.
12. Equipment must comply with the latest requirements per SAE J137 and/or ANSI/ASAE S279 when driven on public roads.

-NOTE-

If the mower is driven on public roads, it must comply with state and local ordinances as well as SAE J137 and/or ANSI / ASAE S279 requirements. Contact your local authorities for regulations and equipment requirements.

13. **DO NOT** operate without the side discharge chute installed and in the down position.
14. Check the blade mounting bolts at frequent intervals for proper tightness.
15. Make sure all hydraulic fluid connections are tight and all hydraulic hoses and lines are in good condition before starting the machine.

2.4 OPERATION CONSIDERATIONS

1. Know the function of all controls and how to stop quickly.
2. Reduce speed and exercise extreme caution on slopes and in sharp turns to prevent tipping or loss of control. Be especially cautious when changing directions on slopes.

WARNING:

DO NOT operate on steep slopes. To check a slope, attempt to back up it (with the cutter deck down). If the machine can back up the slope without the wheels slipping, reduce speed and use extreme caution. ALWAYS FOLLOW OSHA APPROVED OPERATION.

2.4 OPERATION CONSIDERATIONS (CONT'D)

3. To prevent tipping or loss of control, start and stop smoothly, avoid unnecessary turns and travel at reduced speed.
4. When using any attachment, never direct the discharge of material toward bystanders or allow anyone near the machine while in operation.
5. Before attempting to start the engine, with the operator in the seat, disengage power to the cutter deck, place the steering control levers in the neutral position and engage the parking brake.
6. If the mower discharge ever plugs, shut off the engine, remove the ignition key, and wait for all movement to stop before removing the obstruction. Do not use your hand to dislodge the clogged discharge chute. Use a stick or other device to remove clogged material.
7. Be alert for holes, rocks, roots and other hidden hazards in the terrain. Keep away from any dropoff. Beware of overhead obstructions (low limbs, etc.), underground obstacles (sprinklers, pipes, tree roots, etc.). Cautiously enter a new area. Be alert for hidden hazards.
8. Disengage power to the cutter deck before backing up. Do not mow in reverse unless absolutely necessary and then only after observation of the entire area behind the mower.
9. **DO NOT** turn sharply. Use care when backing up.
10. Disengage power to the cutter deck before crossing roads, walks or gravel drives.
11. Mow only in daylight or good artificial light.
12. Take all possible precautions when leaving the machine unattended, such as disengaging the mower, lowering the attachments, setting the parking brake, stopping the engine, and removing the key.
13. Disengage power to the attachments when transporting or when not in use.
14. The machine and attachments should be stopped and inspected for damage after striking a foreign object, and damage should be repaired before restarting and operating the machine.
15. **DO NOT** touch the engine or the muffler while the engine is running or immediately after stopping. These areas may be hot enough to cause a burn.
16. **DO NOT** run the engine inside a building or a confined area without proper ventilation. Exhaust fumes are hazardous and could cause death.

2.5 MAINTENANCE CONSIDERATIONS

1. Never make adjustments to the machine with the engine running unless specifically instructed to do so. If the engine is running, keep hands, feet, and clothing away from moving parts.
2. Remove the key from the ignition switch to prevent accidental starting of the engine when servicing or adjusting the machine.
3. Keep all nuts, bolts and screws tight, to ensure the machine is in safe working condition.
4. Do not change the engine governor settings or overspeed the engine. See the engine operator's manual for information on engine settings.
5. To reduce fire hazard, keep the engine free of grass, leaves, excessive grease, oil and dirt.
6. **Hydraulic fluid is under high pressure.** Keep body and hands away from pinholes or nozzles that eject hydraulic fluid under high pressure. If you need service on your hydraulic system, please see your authorized Scag dealer. Hydraulic fluid under high pressure may have sufficient force to penetrate skin and cause serious injury. If hydraulic fluid is injected into the skin, it must be surgically removed within a few hours by a doctor or gangrene may result.

Section 2

2.6 SAFETY AND INSTRUCTIONAL DECALS

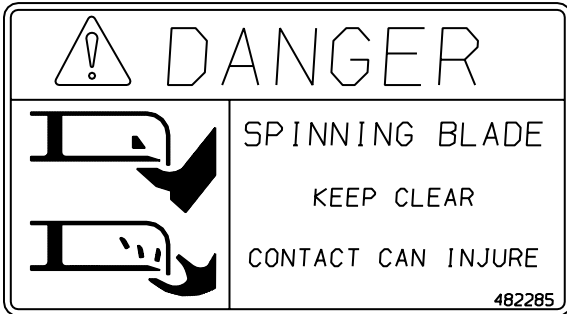

482285



481039

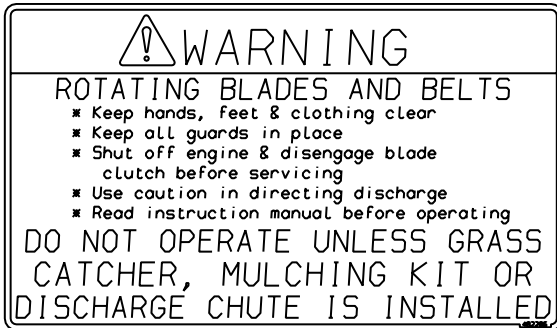

482286



481568

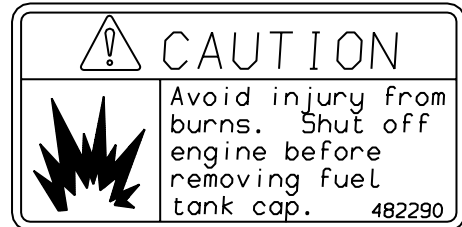

482290

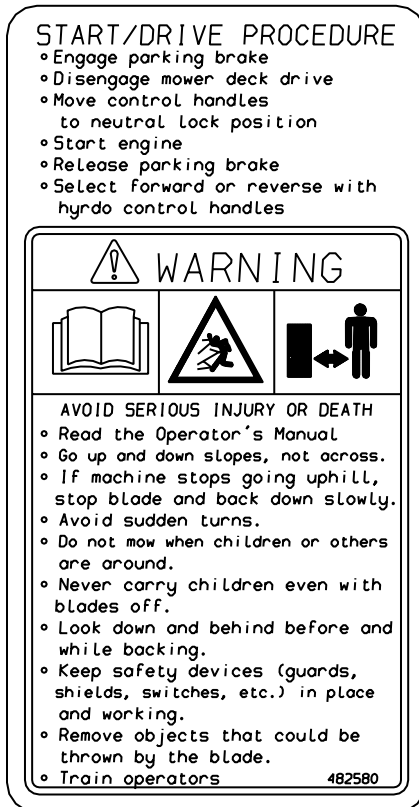

482580

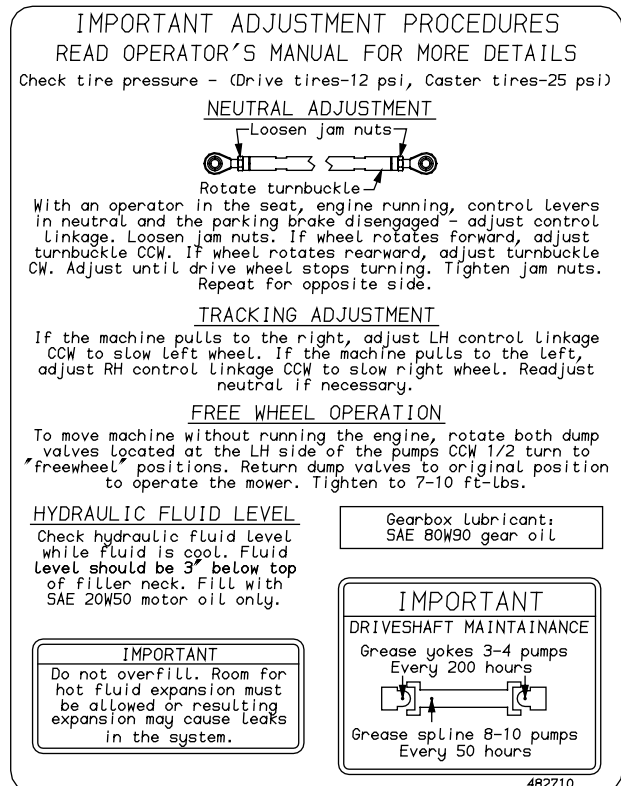

482710

SPECIFICATIONS

SCAG "SABRE TOOTH TIGER" ZERO-TURN RIDER MODEL: STT- 31BSG

ENGINE

General Type:	Heavy duty industrial/commercial
Brand:	Briggs Daihatsu Vanguard Liquid Cooled 31 HP
Model:	DM950G
Horsepower:	31 HP @ 3600 RPM
Type:	water cooled 4 cycle, overhead valve, 3 cylinder, gas engine
Displacement:	952 cc
Cylinders:	3 inline sleeves
Governor:	High-speed flyweight governor, runs faster than engine crankshaft, provides precision speed governing and a steady low idle, 3600 rpm (± 100 rpm), idle set at 1500 rpm
Air Intake Group:	Canister type air filter system.
Exhaust Group:	Single exhaust canister muffler
Fuel Pump Group:	Electric fuel pump with mechanical choke and fuel shutdown solenoid
Oil Pump Group:	Positive displacement Gerotor™ oil pump with remote oil filter, capacity 3.2 U.S. quarts (3.0 ltrs) with oil filter
Valve Group:	Overhead
Electrical/Charging System:	12 volt battery with alternator, solid state ignition with key start, 40 amp regulated charging system using a microprocessor and one ignition coil for each cylinder, solenoid shift type starter

ENGINE DECK

Fuel Tank:	10 gallon (38.0 litres) seamless polyethylene tank with fuel gauge gas cap
Drive Wheels/Tires:	24x12-12 four-ply pneumatic tubeless, radius edge, offset rims to improve operator's view
Parking Brake:	Lever operated interlocked parking brake prevents operation with parking brake engaged
Frame:	Compact tractor frame with structural steel tubing construction

DRIVE SYSTEM

Type:	Hydro drive with two variable displacement pumps and two cast iron motors for independent control of each drive wheel
Hydro Pumps:	Two Hydro-Gear Model BDP 21L pumps with dump valves for movement without running engine
Drive Wheel Motors:	Two 23 cubic inch cast-iron high torque wheel motors
Transmission Belt Idler:	Self-adjusting, self-tightening, sealed bearings
Hydro Fluid Cooling Group:	3 qt. capacity nylon fluid reservoir, uses SAE 20W50 fluid and 10 micron filter
Steering/Travel Control:	Twin lever fingertip steering control with gas shock dampeners for smooth, responsive control to each wheel
Axles:	1-1/4" heavy-duty, tapered motor shafts
Wire Harness:	14 gauge wire
Safety Group:	Seat actuated engine kill, neutral interlock, mower engagement (BBC) switch, parking brake
Instrument Panel:	Voltmeter, water temperature gauge, oil pressure gauge, key switch, throttle, fuses, manual choke, BBC switch (hourmeter located at rear of machine)
Forward Ground Speed Range:	0 to 10.5 mph
Reverse Ground Speed Range:	0 to 5.0 mph

-NOTE-

The machine will travel at 10.5 mph for transport purposes. For best cutting performance the forward travel speed should be adjusted depending upon the cutting conditions.

Date of Issue: July, 2002

Specifications Subject To Change Without Notice

SPECIFICATIONS (CON'T)

SCAG "SABRE TOOTH TIGER" ZERO-TURN RIDER MODEL: STT- 31BSG

CUTTER DECK

Type:	SMST-72A ("Advantage") & SMST-61A ("Advantage") - Floating, adjustable anti-scalping, hybrid design combines out-front and belly-mount designs. "Advantage" - special extended front edge allows Bahia or other tough grasses to enter the deck standing upright for a clean cutting.
Construction:	10-gauge steel top reinforced with 7 gauge support plate, deck skirt is 7 gauge steel
True Cutting Width:	72" cutter deck = 71.5 inches (181.6 cm); 61" cutter deck = 61.0" (155.0cm)
Cutting Height Adjustment:	Foot-operated pedal adjustment from operator's seat, 1" to 6" in 1/4" increments
Cutter Blades:	72" = Three (3) 24" blades; 61" = Three (3) 21" blades
Cutter Deck Drive:	Drive shaft to 90 degree gear box
Blade Engagement:	Electric blade engagement clutch with control panel knob
Discharge Opening:	Extra wide 11.5" discharge opening with spring loaded discharge chute
Caster Wheels:	13 x 6 caster wheels with tapered roller bearing pivots and axles
Spindles:	Heavy duty 1-1/8" top dimension spindle shaft, cast housing, taper roller bearing, low maintenance with top access grease fitting and grease overfill relief poppet
Spindle Pulleys:	Cast-iron with easily removed taper hubs
Cutter Deck Belts:	B-section with Kevlar cord
Anti-Scalp Rollers:	Two front, two rear 4-1/2" adjustable, two rear 12" fixed

ADDITIONAL SPECIFICATIONS

Seat:	Thick padded seat cushions with special springs. Padded arm rests, lever adjustment forward and back.
-------	---

APPROXIMATE DIMENSIONS

	72"	61"
Length:	92.0"	92.0"
Tracking Width:	56.0"	56.0"
Width:	83.5"	72.0"
Width (with discharge chute up):	73.0"	62.0"
Height:	47.0"	47.0"
Turning Radius:	zero radius turning	zero radius turning
Weight:	1635 lbs.	1600 lbs.

PRODUCTIVITY

The following chart will aid you in determining how many acres your Scag mower will cut per day.

The chart is an estimate based on 8 hours of cutting time at 6 MPH with an allowance for overlap and turns has been calculated in.

Cutting Width:	61" 72"
Acres Per Day:	23.6 28

Date of Issue: July, 2002

Specifications Subject To Change Without Notice

OPERATING INSTRUCTIONS

CAUTION:

Do not attempt to operate this mower unless you have read this manual. Learn the location and purpose of all controls and instruments before you operate this mower.

4.1 CONTROLS AND INSTRUMENT IDENTIFICATION

Before operating the mower, familiarize yourself with all mower and engine controls. Knowing the location, function and operation of these controls is important for safe and efficient operation of the mower.

1. **Ignition Switch (Figure 4-1).** The ignition switch is used to start the engine and has three positions; OFF, ON, and START.
2. **Mower Deck Switch (Figure 4-1).** Used to engage and disengage the mower drive system. Pulling up on the switch will engage the deck drive. Pushing down on the switch will disengage the deck drive.
3. **Engine Choke Control (Figure 4-1).** Used to start a cold engine.
4. **Engine Throttle Control (Figure 4-1).** Used to control the engine speed. Pushing the lever forward increases engine speed. Pulling the lever back decreases engine speed. Full back position is the IDLE position. Full forward is the cutting position.

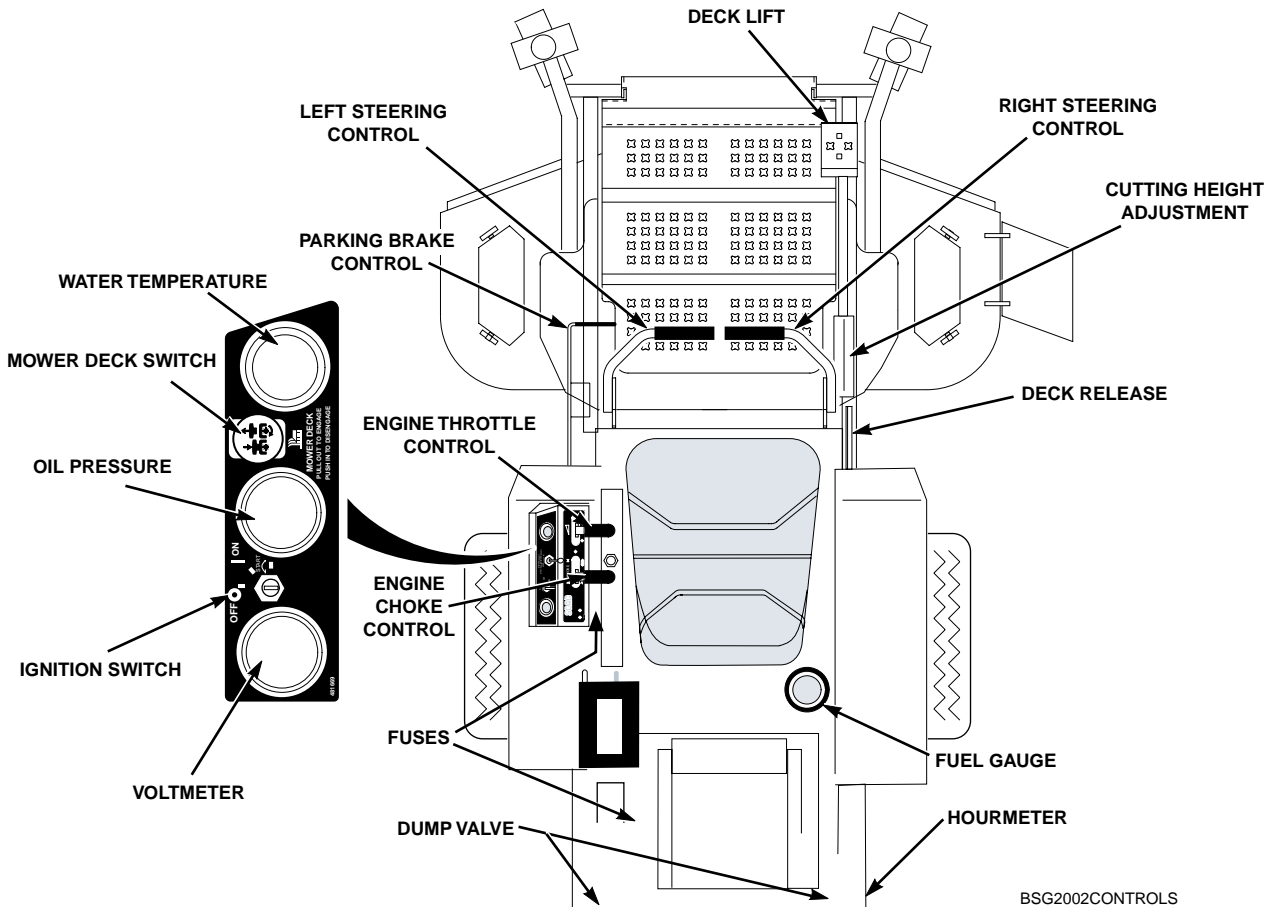

Figure 4-1 Controls and Instruments

Section 4

5. **Voltmeter (Figure 4-1).** Indicates the condition of the charging system. When the engine is running, in normal operating conditions, the needle should be in the 12 to 14 volt range.
6. **Oil Pressure (Figure 4-1).** Indicates engine oil pressure. Reference the engine operator's manual for further information.
7. **Hourmeter (Figure 4-1).** Indicates the number of hours the engine has been operated. It operates whenever the engine is running. It can be used to keep track of maintenance intervals and the amount of time required to perform various tasks.
8. **Fuse Holders (Figure 4-1).** There are two 20-amp fuses and one 40-amp fuse that protect the mower's electrical system. To replace fuses, pull fuse out of the socket and install a new fuse.
9. **Left Steering Control (Figure 4-1).** Used to control the mower's left wheel when traveling forward or reverse.
10. **Right Steering Control (Figure 4-1).** Used to control the mower's right wheel when traveling forward or reverse.
11. **Parking Brake Control (Figure 4-1).** Used to engage and disengage the parking brakes. Pull the lever back to engage the parking brakes. Push the lever forward to disengage the parking brakes.
12. **Fuel Tank Gauge (Figure 4-1).** Indicates the amount of fuel in the fuel tank.
13. **Dump Valve Control Levers (Figure 4-2).** Located on the hydraulic pumps, used to "free-wheel" the mower. Rotating the levers clockwise until they stop allows the unit to move under hydraulic power. The levers must be in this position and torqued to 10ft/lbs during operation of the mower. Rotating the levers counter-clockwise allows the mower to be moved by hand (free-wheeling).
14. **Deck Lift Foot Lever (Figure 4-1).** Used to raise and lower the cutter deck.

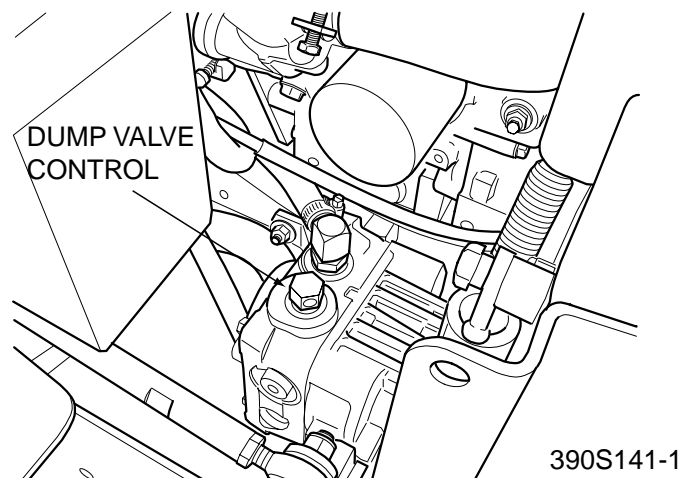

Figure 4-2 Dump Valve Control

15. **Cutting Height Adjustment (Figure 4-1).** Used to set the cutter deck at the desired cutting height.
16. **Deck Release Lever (Figure 4-1).** Used to lock the cutter deck in the transport position. Push the foot pedal forward and lift up on the release lever to release the cutter deck for normal mowing.
17. **Temperature Gauge (Figure 4-1).** Indicates the operating temperature of the engine.

4.2 SAFETY INTERLOCK SYSTEM

The mower is equipped with a safety interlock system that prevents the engine from starting unless the deck drive is disengaged, the parking brake is engaged, the steering control levers are in the neutral position and the operator is in the seat. The interlock system shuts off the engine if the operator leaves the seat with the steering control levers not in the neutral position and/or the cutter blades engaged and the parking brake not engaged.

WARNING:

Never operate the mower with the interlock system disconnected or malfunctioning. Do not disengage or bypass any switch; injury to yourself and others or property damage could result.

4.3 INITIAL RUN-IN PROCEDURES (First Day of Use or Approximately 10 Hours)

1. Check all belts for proper alignment and wear at 2, 4 and 8 hours.
2. Change the engine oil and oil filter after the first 5 hours of operation. (See Section 7.4.)
3. Check hydraulic oil level in reservoir. (See Section 7.3.)
4. Check for loose hardware. Tighten as needed.
5. Check interlock system for proper operation. (See Section 4.2.)
6. Check tire pressure. Adjust pressure if necessary. (See Section 7.10)

4.4 STARTING THE ENGINE



CAUTION:

DO NOT USE STARTING FLUIDS. Use of starting fluids in the air intake system may be potentially explosive or cause a “runaway” engine condition that could result in engine damage and/or personal injury.

1. Be sure the fuel shutoff valve, located behind the operator's seat, is completely open. (See section 7.5.)
2. Sit in the operator's seat and place the steering control levers in the neutral position.
3. Engage the parking brake.
4. Place the PTO switch in the disengaged position.
5. If the engine is cold, choke the engine as needed.
6. Move the engine throttle control to about half engine speed.

7. Turn the ignition key to the START position and release the key as soon as the engine starts. Do not hold the key in the START position for more than 15 seconds at a time. Allow at least 60 seconds between each cranking attempt to prevent overheating of the starter motor. Prolonged cranking can damage the starter motor and shorten battery life.
8. Allow engine to warm before operating the mower.

4.5 GROUND TRAVEL AND STEERING

-IMPORTANT-

If you are not familiar with the operation of a machine with lever steering and/or hydrostatic transmissions, the steering and ground speed operations should be learned and practiced in an open area, away from buildings, fences, or obstructions. Practice until you are comfortable with the handling of the machine before attempting to mow. Learn the operation on flat ground before operating on slopes.

-IMPORTANT-

Start practicing with a slow engine speed and slow forward travel.

Learn to feather the steering controls to obtain a smooth operating action.

Practice operating the mower until you are comfortable with the controls before proceeding to mow.

Forward Travel

To travel forward with the mower, disengage the parking brake and slowly push the steering control levers forward an equal distance. The further the steering control levers are pushed forward the greater the forward speed will be. To increase the speed, push the steering control levers further forward and to decrease the speed, pull the steering control levers back.

To stop the forward travel, pull the steering control levers back to the neutral position.

Section 4

To steer the mower left while traveling forward, pull the left steering lever back. The further the lever is pulled back, the quicker the mower will turn left.

To steer the mower right while traveling forward, pull the right steering control lever back. The further the lever is pulled back, the quicker the mower will turn right.

-NOTE-

Smooth operation of the steering levers will produce smooth mower operation. While learning the operation of the steering controls, keep the travel speed low.

-IMPORTANT-

Do not travel forward over a curb. The mower will hang up on the curb. Raise the deck and travel backwards over the curb at a 45 degree angle. (see section 4.13 for cutter deck raising instructions)

Reverse Travel

CAUTION:

Disengage power to the mower before backing up. Do not mow in reverse unless absolutely necessary and then only after observation of the entire area behind the mower.

CAUTION:

Before backing up, observe the rear for persons and obstructions. Clear the area before backing up. Possible injury or property damage could occur.

To travel in reverse, pull both handles back. Keep the travel speed low while traveling in reverse.

-NOTE-

The mower may not travel straight in reverse. Slight adjustments may need to be made using the steering controls.

To steer left while traveling in reverse, allow the left steering control lever to move forward. The further the control is allowed to move forward, the quicker the mower will turn left.

To steer right while traveling in reverse, allow the right steering control lever to move forward. The further the control is allowed to move forward, the quicker the mower will turn right.

To stop the reverse travel, allow the steering control levers to return to the neutral position. If the mower is to be parked, engage the parking brake.

4.6 ENGAGING THE DECK DRIVE (CUTTER BLADES)

1. Set the throttle at about 3/4 speed. Do not attempt to engage the deck drive at high speed as this shortens the electric clutch life — use only moderate engine speed when engaging the deck drive.
2. Engage the deck drive by pulling out on the yellow switch, located on the instrument panel, (Figure 4-3) to the engage position.

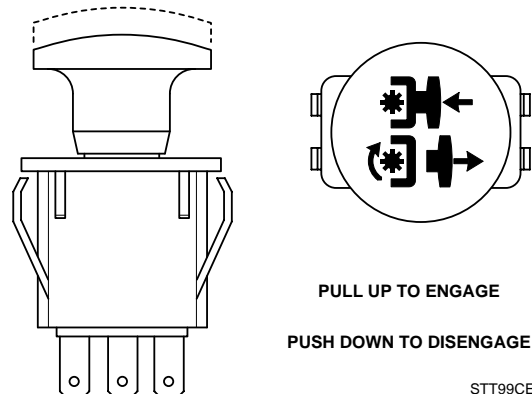

Figure 4-3 Cutter Engage Switch

-NOTE-

A squealing noise may be heard when engaging or disengaging the deck drive. It is caused by the electric clutch plates meshing as the mower comes up to speed.

3. To disengage the deck drive, push the switch in to the disengage position.

4. Always operate the engine at full throttle to properly maintain cutting speed. If the engine starts to lug down, reduce the forward speed and allow the engine to operate at maximum RPM.

4.7 HILLSIDE OPERATION

WARNING:

DO NOT operate on steep slopes. To check a slope, attempt to back up it (with the cutter deck down). If the machine can back up the slope without the wheels slipping, reduce speed and use extreme caution. ALWAYS FOLLOW OSHA APPROVED OPERATION.

1. The mower has been designed for good traction and stability under normal mowing conditions. However, caution must be used when traveling on slopes, especially when the grass is wet. Wet grass reduces traction and steering control.
2. To prevent tipping or loss of control, start and stop smoothly, avoid unnecessary turns and travel at reduced speed.
3. Keep tires properly inflated.

4.8 PARKING THE MOWER

1. Place the steering control levers in the neutral position.
2. Disengage the cutter blades
3. Slow the engine to idle speed.
4. Engage the parking brake.
5. Turn the ignition key to the OFF position and remove the key.

4.9 AFTER OPERATION

1. Wash the entire mower after each use. Do not use high pressure spray or direct the spray onto electrical components.

-IMPORTANT-

Do not wash a hot or running engine. Cold water will damage the engine. Use compressed air to clean the engine if it is hot.

2. Keep the entire mower clean to inhibit serious heat damage to the engine or hydraulic oil circuit.
3. Check the drive belts for proper alignment and any signs of wear. Correct and adjust if necessary.

DANGER:

To avoid injury from burns, allow the mower to cool before removing the fuel tank cap and refueling.

4. After the mower has cooled down, fill the fuel tank with fresh, clean fuel at the end of every day of operation.
5. Check the tire pressure. Adjust pressure if necessary.

Section 4**4.10 REMOVING CLOGGED MATERIAL**

**DANGER:
ROTATING BLADES**

NEVER PUT YOUR HANDS INTO THE DISCHARGE CHUTE FOR ANY REASON! Shut off the engine and remove the key and only then use a stick or similar object to remove material if clogging has occurred.

1. If the discharge chute becomes clogged, shut off the engine and remove the ignition key. Using a stick or similar item, dislodge the clogged material. Then resume normal mowing.

4.11 MOVING MOWER WITH ENGINE STOPPED

To “free-wheel” or move the mower around without the engine running, place the dump valve levers in the FREE-WHEEL position (Figure 4-2, Page 11). Disengage the parking brake and move the mower by hand. The dump valves must be returned to the DRIVE position and torqued to 10ft/lbs to drive the mower.

4.12 RECOMMENDATIONS FOR MOWING

1. Do not mow with dull blades. A dull blade will tear grass, resulting in poor lawn appearance, and require extra power.
2. The discharge chute must not be removed and must be kept in the lowest position to deflect grass clippings and thrown objects downward. Direct the side discharge away from sidewalks or streets to minimize cleanup of clippings. When mowing close to obstacles, direct the discharge away from the obstacles to reduce the chance of property damage by thrown objects.

WARNING

DO NOT OPERATE WITHOUT DISCHARGE CHUTE, MULCHING KIT, OR ENTIRE GRASS CATCHER INSTALLED

3. Cut grass when it is dry and not too tall. Do not cut grass too short (cut off 1/3 or less of existing grass for best appearance). Mow frequently.
4. Keep mower and discharge chute clean.
5. When mowing wet or tall grass, mow the grass twice. Raise the mower to the highest setting for the first pass and then make a second pass to the desired height.
6. Use a slow travel speed for trimming purposes.
7. Operate the engine at full throttle for best cutting. Mowing with a lower RPM causes the mower to tear the grass. The engine is designed to be operated at full speed.
8. Use the alternate stripe pattern for best lawn appearance. Vary the direction of the stripe each time the grass is mowed to avoid wear patterns in the grass.

4.13 ADJUSTING CUTTING HEIGHT

The mower deck can be adjusted from a height of 1-inch to 6 inches at 1/4-inch intervals. To adjust the cutting height:

1. Disengage the power to the cutter blades.
2. Push the cutting height adjustment foot pedal all the way forward using your right foot until it locks in place. (Figure 4-6).
3. Insert the lanyard pin into the cutting height index at the desired cutting height. Push forward on the deck lift foot lever, hold in place and lift up on the deck release lever, (Figure 4-7). Slowly release the foot pedal. A deck height decal is located on the cutting height index as an aid in adjusting the deck to the desired height. (Figure 4-6).

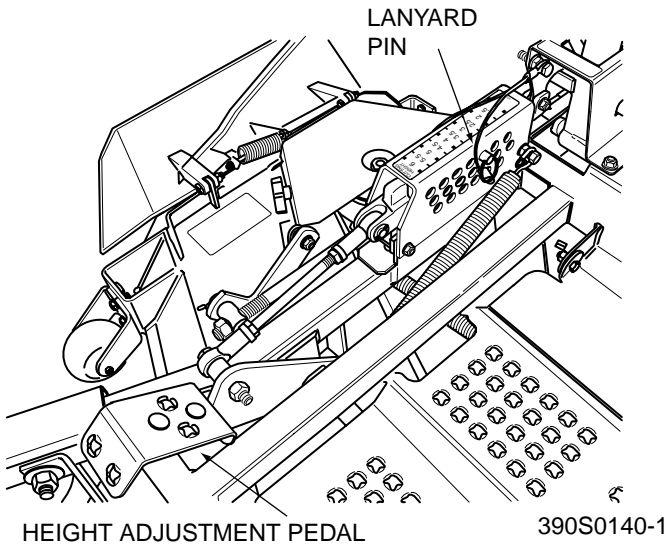

Figure 4-6 Deck Release Lever

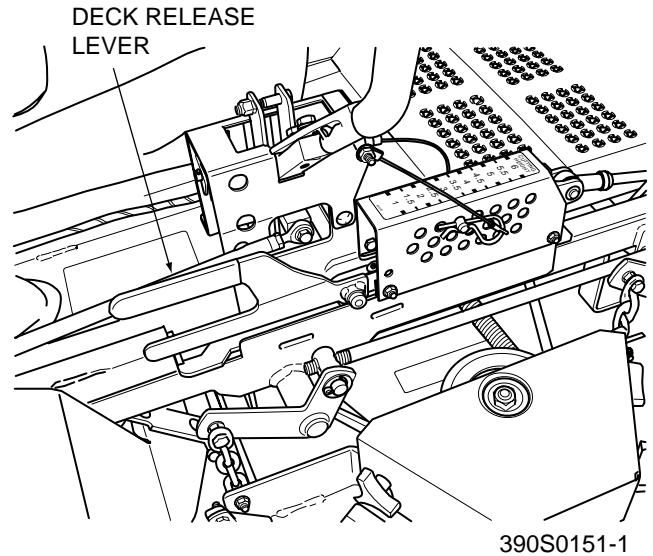

Figure 4-7 Adjusting Cutting Height

4.14 Towing (optional hitch accessory)

1. Never allow children or others in or on towed equipment.
2. Tow only with a machine that has a hitch designed for towing. Do not attach towed equipment except at the hitch point.
3. Follow manufacturer's recommendations for weight limit for towed equipment. 250lbs. maximum towing weight.
4. Never tow on slopes. The weight of the towed equipment may cause loss of traction and loss of control.
5. Travel slowly and allow extra distance to stop.
6. Zero turning with a trailer attached could cause damage to the trailer or mower.

! WARNING

MAXIMUM TOWED WEIGHT
NOT TO EXCEED 250 LBS
DO NOT CARRY PASSENGERS



READ THE OPERATOR'S MANUAL

482610

TROUBLESHOOTING CUTTING CONDITIONS

CONDITION	CAUSE	CURE
<p>Stringers - Occasional Blades of Uncut Grass</p> <p style="text-align: center;">Width of Deck</p> <p style="text-align: right; font-size: small;">SGB020</p>	Low engine RPM	Run engine at full RPM
	Ground speed too fast	Slow speed to adjust for conditions
	Wet grass	Cut grass after it has dried out
	Dull blades, incorrect sharpening	Sharpen blades
	Deck plugged, grass accumulation	Clean underside of deck
	Belts slipping	Adjust belt tension
<p>Streaking - Strips of Uncut Grass in Cutting Path</p> <p style="text-align: center;">Width of Deck</p> <p style="text-align: right; font-size: small;">SGB018</p>	Dull, worn blades	Sharpen blades
	Incorrect blade sharpening	Sharpen blades
	Low engine RPM	Run engine at full RPM
	Belt slipping	Adjust belt tension
	Deck plugged, grass accumulation	Clean underside of deck
	Ground speed too fast	Slow speed to adjust for conditions
	Wet grass	Cut grass after it has dried out
	Bent blades	Replace blades
<p>Streaking - Strips of Uncut Grass Between Cutting Paths</p> <p style="text-align: center;">Width of Deck Width of Deck</p> <p style="text-align: center; font-size: small;">SGB019</p>	Not enough overlapping between rows	Increase the overlap of each pass

TROUBLESHOOTING (CONT'D)

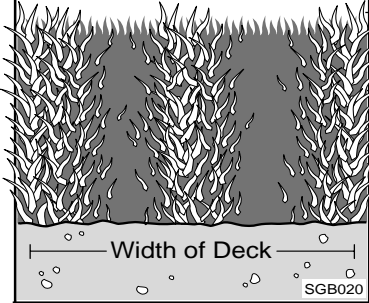
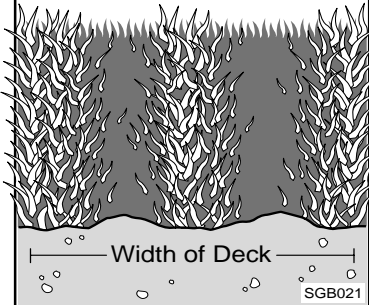
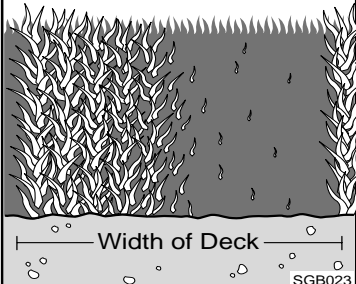
CONDITION	CAUSE	CURE
<p>Uneven Cut on Flat Ground - Wavy High-Low Appearance, Scalloped Cut, or Rough Contour</p> 	Lift worn from blade	Replace blade
	Blade upside down	Mount with cutting edge toward ground
	Deck plugged, grass accumulation	Clean underside of deck
	Too much blade angle (deck pitch)	Adjust pitch and level
	Deck mounted improperly	See your authorized SCAG dealer
	Bent spindle area	See your authorized SCAG dealer
	Dull blade	Sharpen blade
<p>Uneven Cut on Uneven Ground - Wavy Appearance, High-Low Scalloped Cut, or Rough Contour</p> 	Uneven ground	May need to reduce ground speed, raise cutting height, and/or change direction of cut
<p>Sloping Ridge Across Width of Cutting Path</p> 	Tire pressures not equal	Check and adjust tire pressure
	Wheels uneven	Check and adjust tire pressure
	Deck mounted incorrectly	See your authorized SCAG dealer
	Deck not level side-to-side	Check for level and correct

TROUBLESHOOTING (CONT'D)

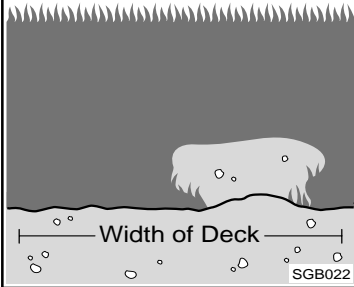
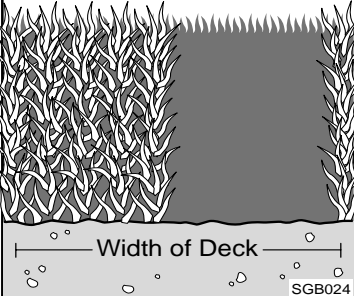
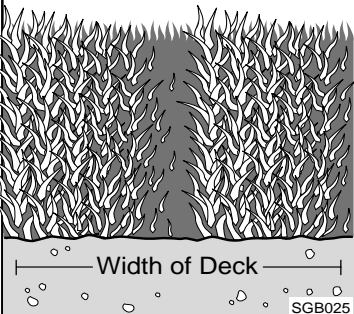
CONDITION	CAUSE	CURE
<p>Scalping - Blades Hitting Dirt or Cutting Very Close to the Ground</p>  <p>Width of Deck SGB022</p>	Low tire pressures	Check and adjust pressures
	Ground speed too fast	Slow speed to adjust for conditions
	Cutting too low	May need to reduce ground speed, raise cutting height, change direction of cut, and/or change pitch and level
	Rough terrain	May need to reduce ground speed, raise cutting height, and/or change direction of cut
	Ground speed too fast	Slow speed to adjust for conditions
<p>Step Cut - Ridge in Center of Cutting path</p>  <p>Width of Deck SGB024</p>	Blades not mounted evenly	Adjust pitch and level
	Bent blade	Replace blade
	Internal spindle failure	See your authorized SCAG dealer
	Mounting of spindle incorrect	See your authorized SCAG dealer
<p>Slope Cut - Sloping Ridges Across Width of Cutting Path</p>  <p>Width of Deck SGB025</p>	Bent spindle mounting area	See your authorized SCAG dealer
	Internal spindle failure	See your authorized SCAG dealer
	Bent deck housing	See your authorized SCAG dealer

ADJUSTMENTS

6.1 PARKING BRAKE ADJUSTMENT

! WARNING:

Do not operate the mower if the parking brake is not operable. Possible severe injury could result.

The parking brake linkage should be adjusted whenever the parking brake lever is placed in the "ENGAGE" position and the parking brake will not prevent the mower from moving. If the following procedures do not allow you to engage the parking brake properly, contact your Scag dealer for further brake adjustments.

1. Position a floor jack under the rear of the machine. Raise the machine and support it to prevent it from falling. Block the caster wheels to prevent the machine from moving. Remove the drive wheels.
2. With the brake lever in the disengaged position, check the distance between the top of the frame tube and the bottom of the brake handle. The distance should be 2" to 2-1/4" (See Figure 6-1).
3. If the distance is not at the specified measurement, adjust by loosening the jam nuts at both ends of the brake control rod and turning the rod until the proper distance is achieved. (See Figure 6-1). Tighten the jam nuts.
4. With the brake in the engaged position, check the distance between the lower nut on the brake actuator rod and the brake actuator lever on the LH side of the machine. The distance should be 1/8" (See Figure 6-2).
5. If the distance is not at the specified measurement, loosen the jam nut at the clevis on the top of the brake actuator rod (See Figure 6-2).
6. Turn the bolt at the bottom of the brake actuator lever until the 1/8" measurement is achieved and tighten the jam nut at the clevis on the brake actuator rod. (See Figure 6-2).

7. Repeat steps 4-6 on the RH side of the machine.
8. Replace the drive wheels and test the brake.

-NOTE-

If this procedure does not achieve proper brake adjustment, please contact your authorized Scag dealer.

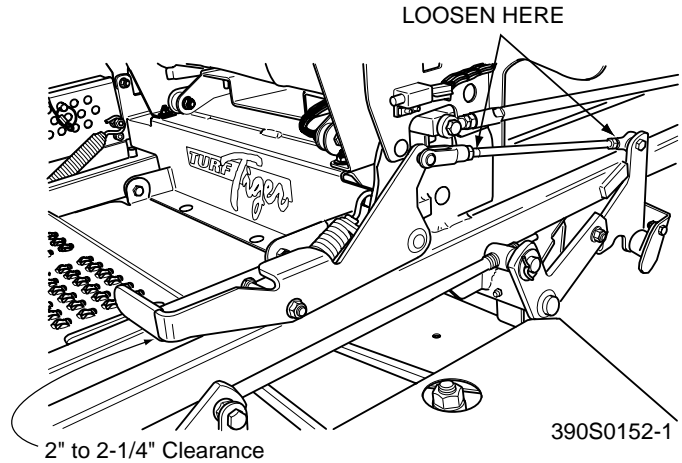

Figure 6-1. Brake Adjustment

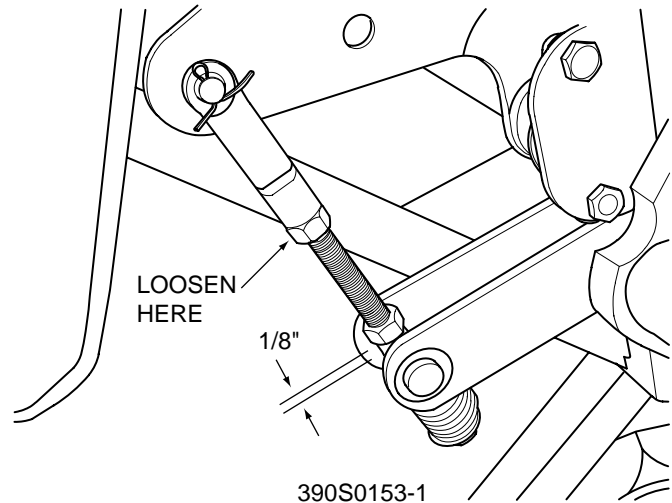

Figure 6-2. Brake Rod Adjustment

6.2 TRAVEL ADJUSTMENTS

Neutral or tracking adjustments will need to be made if:

- A. The steering control levers are in the neutral position and the machine creeps forward or backward. (Neutral Adjustment, See Page 21).

Section 6

- B. The steering control levers are in the full forward position and the mower pulls to one side or the other when traveling in a forward direction. (Tracking Adjustment, See Page 22).

Neutral Adjustment

1. Be sure the dump valve levers are in the run position and the steering control levers are in the neutral lock position.
2. With an operator in the seat, start the engine and disengage the parking brake.
3. Run the engine at full operating speed and check if the machine creeps forward or backwards.
4. Adjust the RH wheel by loosening the jam nuts on the steering control rod and turning the rod until the drive wheel turns in the forward direction. Turn the rod back until the drive wheel stops moving. Turn the rod an additional 1/2 turn. (See Figure 6-3).
5. Tighten the jam nuts and repeat for the LH wheel. (See Figure 6-4).
6. Actuate the steering control levers forward and reverse several times and return them to the neutral position.
7. Check that the drive wheels remained in neutral and readjust if necessary.
8. Check that the steering control levers hit the stop before the pumps reach full stroke. Adjust as needed.

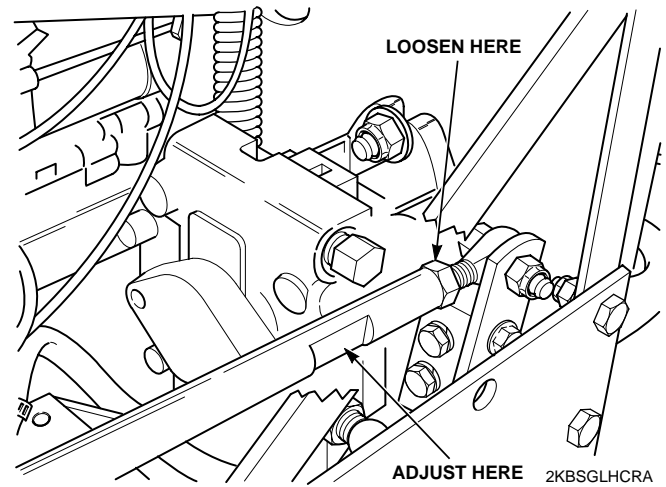
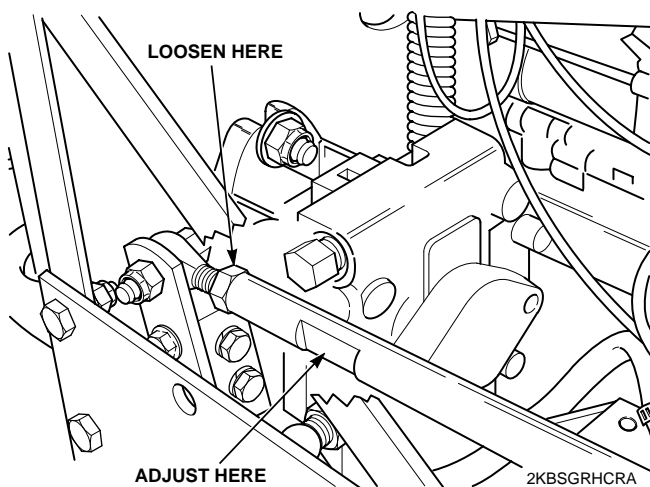
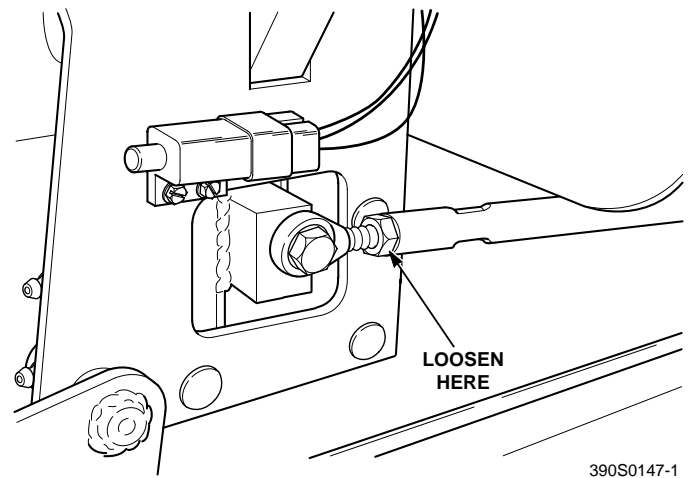
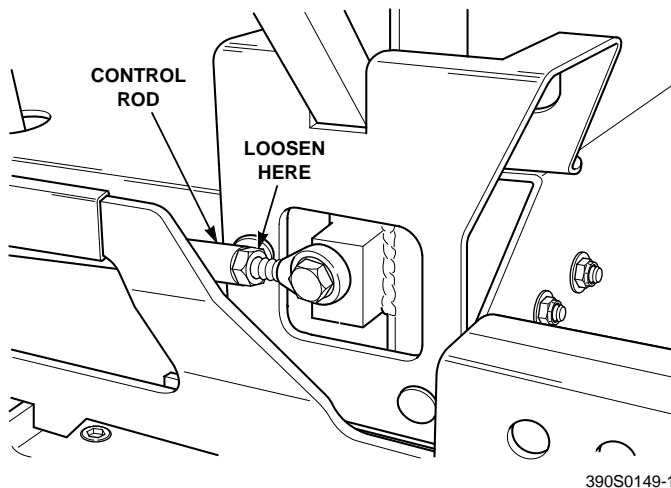

Figure 6-3. RH Steering Control Rod Adjustment

Figure 6-4. LH Steering Control Rod Adjustment

Tracking Adjustment



CAUTION:

Stop the engine and remove the key from the ignition before making any adjustments. Wait for all moving parts to come to a complete stop before beginning work.



CAUTION:

The engine and drive unit can get hot during operation causing burn injuries. Allow engine and drive components to cool before making any adjustments.

-NOTE-

Before proceeding with this adjustment, be sure that the caster wheels turn freely and that the tire pressure in the drive wheels is correct. If the tire pressure is not correct or the caster wheel pivots are binding, the machine will pull to one side.

1. If at full speed the mower pulls right, it is an indication that the left wheel is turning faster than the right wheel. To adjust this condition, proceed as follows:
 - A. Stop the machine and place the steering control levers in the neutral position. Loosen the lock nuts securing the ball joints at each end of the LH steering control rod. Rotate the control rod to lengthen the rod and tighten the lock nuts. This will cause the control rod to stroke the LH pump less, slowing down the LH wheel. (See Figure 6-4)

-NOTE-

If after making the adjustment as outlined in step 1A, the machine creeps forward or backward, the neutral adjustment must be made as described on page 21.

2. If at full speed the mower pulls left, it is an indication that the right wheel is turning faster than the left wheel. To adjust this condition, proceed as follows:

- A. Stop the machine and place the steering control levers in the neutral position. Loosen the lock nuts securing the ball joints at each end of the RH steering control rod. Rotate the control rod to lengthen the rod and tighten the lock nuts. This will cause the control rod to stroke the RH pump less, slowing down the RH wheel. (See Figure 6-3)

-NOTE-

If after making the adjustment as outlined in step 2A, the machine creeps forward or backward, the neutral adjustment must be made as described on page 21.

6.3 THROTTLE CONTROL AND CHOKE ADJUSTMENTS

These adjustments must be performed by your Scag dealer to ensure proper and efficient running of the engine. Should either need adjustment, contact your authorized Scag service center.

6.4 BELT ADJUSTMENT



WARNING:

Before removing any guards, shut the engine off and remove the ignition key.

All drive belts and cutter deck belts are spring loaded and self-tensioning. The belts should be checked periodically for proper alignment and wear.

6.5 BELT ALIGNMENT

Belt alignment is important for proper performance of your Scag mower. If you experience frequent belt wear or breakage, see your authorized Scag service center for belt adjustment.

6.6 CUTTER DECK ADJUSTMENTS

Cutter deck level, pitch and height are set at the factory. However, if these adjustments should ever need to be made, the following procedures will aid in obtaining the proper cutter deck adjustment.

-NOTE-

Before proceeding with the cutter deck adjustments, be sure that all tires are properly inflated.

Cutter Deck Level

The cutter deck should be level from side-to-side for proper cutting performance. To check for level, be sure that the mower is on a flat, level surface, the tires are properly inflated and the cutter deck is set at the most common cutting height that you will use. On the RH side of the machine, check the distance from the bottom of the cutter deck to the floor. Next check the distance from the bottom of the cutter deck to the floor on the LH side of the machine. Both measurements should be the same. If the two measurements are different, the cutter deck level must be adjusted as follows:

1. On the front LH side of the cutter deck locate the cutter deck adjusting bolt. (See Figure 6.5)

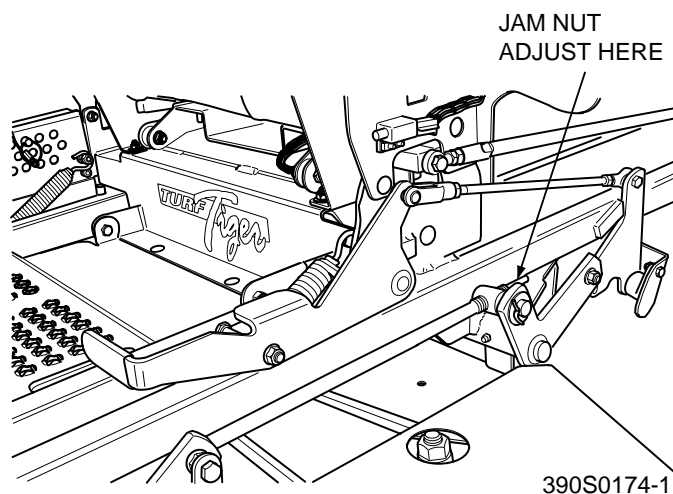

Figure 6-5. Cutter Deck Adjustment

2. Loosen the elastic stop nut and move the bolt up or down in the slot to adjust the cutter deck until the distance from the bottom of the cutter deck to the floor is the same as the measurement on the RH side of the machine.

3. Tighten the elastic stop nut to secure the cutter deck in the proper position.

Cutter Deck Pitch

The pitch of the cutter deck should be 1/4" down toward the front of the cutter deck for proper cutting performance. To check for proper deck pitch, be sure that the mower is on a flat, level surface and the tires are properly inflated. Use the following procedures, however, measure from the top of the cutter deck rather than the bottom edge. Lay a straight edged object on the top of the Advantage cutter deck, protruding towards the front of the machine, when measuring the front height.

Check the distance from the top of the cutter deck to the floor at the rear RH side of the cutter deck directly behind the cutter deck hanging chains. Next check the distance from the top of the cutter deck to the floor at the front RH side of the cutter deck directly in front of the cutter deck hanging chains. The measurement at the front of the cutter deck should be 1/4" lower than the measurement at the rear of the deck. Make these measurements at the LH side of the cutter deck also. If the measurement at the front of the deck is not 1/4" lower, the cutter deck pitch must be adjusted as follows:

1. Loosen the jam nuts on both adjusting rods. (See Figure 6-5)
2. Using a wrench on the spring compression nut (See Figure 6-5) turn the adjusting rods until the 1/4" forward pitch is obtained on both the RH and the LH side of the cutter deck. Tighten both jam nuts.

-NOTE-

To prevent the cutter deck from teetering, all four cutter deck hanging chains must have tension on them. If all four chains do not have tension on them and the deck teeters, you must readjust the cutter deck as outlined in the procedures above.

Cutter Deck Height

The cutter deck height adjustment is made to ensure that the cutter deck is cutting at the height indicated on the cutting height index gauge. To check for proper deck height, be sure that the mower is on a flat, level surface and the tires are properly inflated.

1. Place the cutter deck in the transport position. Loosen the jam nuts on both ends of the deck height control rod. (See Figure 6-6)

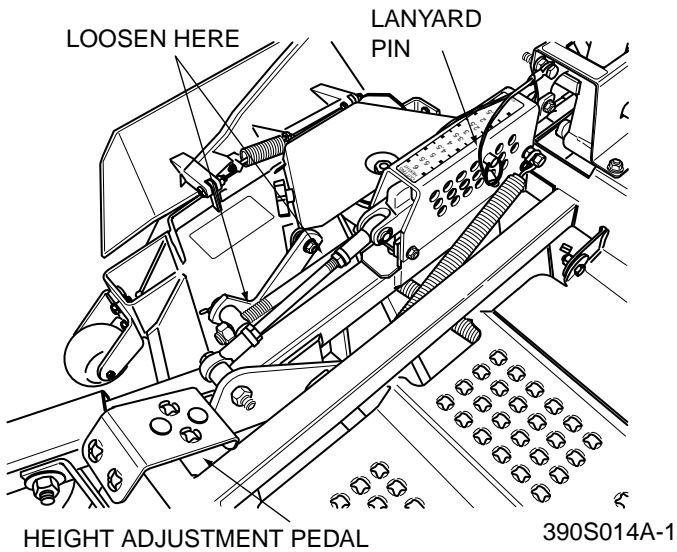

Figure 6-6. Cutter Deck Height Adjustment

2. Turn the control rod (See Figure 6-6) until there is a 1/4" space between the rear deck stop and the top of the cutter deck. (See Figure 6-7). Tighten the jam nuts on the control rod.

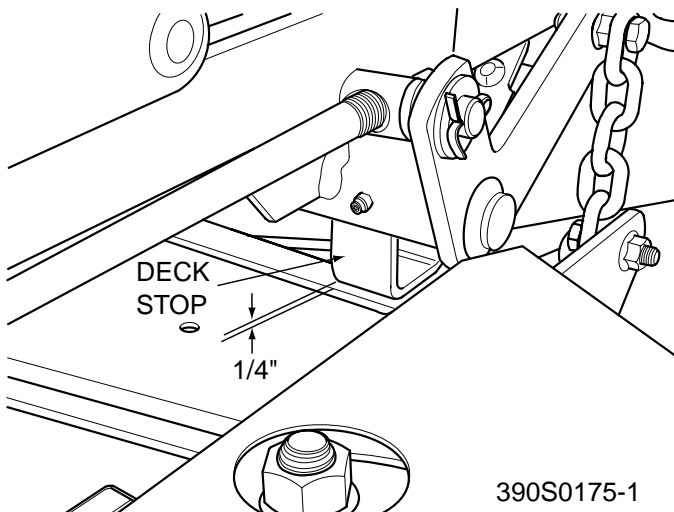

Figure 6-7. Cutter Deck Stop

3. Check the cutter deck cutting height by placing the lanyard pin in the 3" position on the cutting height index. Release the deck from the transport position and allow the deck to move to the 3" cutting height position.
4. Check the measurement from the floor to the cutter blade tip. If the measurement is not at 3", an adjustment can be made using the deck height control rod. (See Figure 6-6)

-NOTE-

If an adjustment has to be made, be sure that the cutter deck can easily be locked into the transport position.

Custom-Cut Baffle Adjustment

The Custom-Cut Baffle is designed to deliver optimum airflow and superior cutting performance in any type of grass. The Custom-Cut Baffle can be raised or lowered to precisely tailor the deck's performance for the type of grass being cut. The baffle can be set in three (3) different positions for optimum performance.

- A. 3" Position - baffle removed. (See Figure 6.9). With the baffle removed, the Advantage cutter deck will deliver the best quality-of-cut in very tall, wiry, tough to cut grass.
- B. 3-1/2" Position (factory setting) - baffle is installed using the bottom set of holes on the Custom Cut Baffle. (See Figure 6.10). For general purpose cutting, place the Custom Cut Baffle in the 3-1/2" position. This gives the best mix of cutting performance in all types of grass.
- C. 4" Position - baffle is installed using the top set of holes on the Custom Cut Baffle. (See Figure 6.11). Placing the baffle in the 4" setting will enhance fall cutting (leaf pickup) and reduce cutter deck "blowout".

Section 6

To adjust the Custom-Cut Baffle height:

1. Place the cutter deck in the transport position.
2. Remove the hardware securing the Custom-Cut Baffle to the cutter deck. (See Figure 6.8).

-NOTE-

Hardware location used in the illustrations are for reference only. Location of hardware may vary depending on cutter deck size.

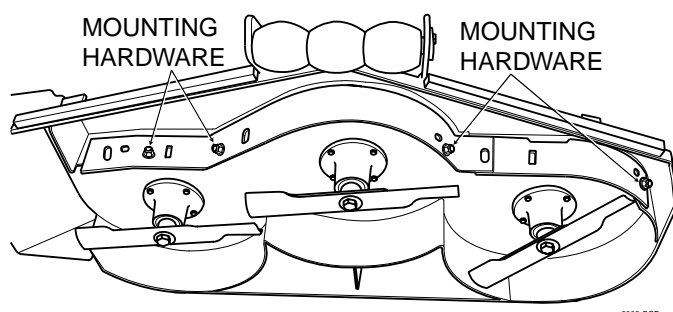

Figure 6-8. Custom Cut Baffle

3. Move the Custom-Cut Baffle to desired position. (See Figures 6.9 through 6.11 for position).
4. Reinstall the mounting hardware as shown. (See Figures 6.10 though 6.11). Torque hardware to 39ft.lbs.

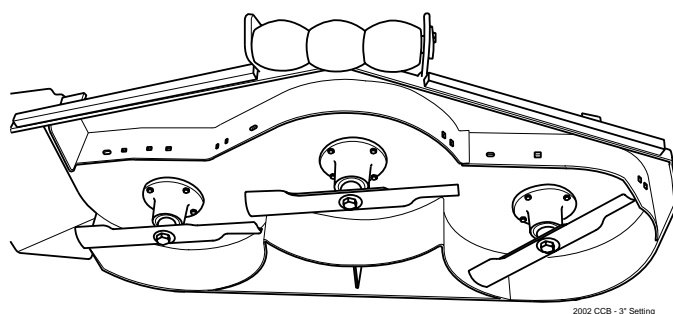

Figure 6-9. 3" Custom Cut Baffle Position

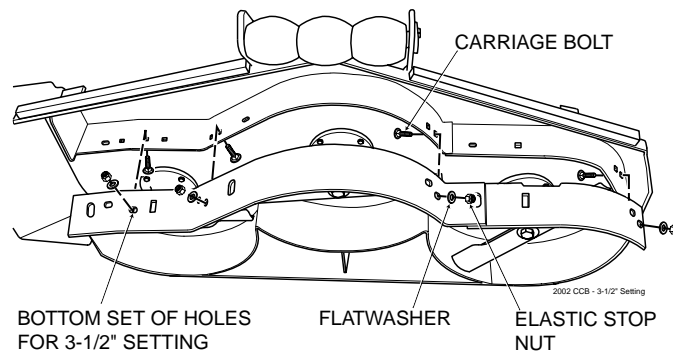

Figure 6-10. 3-1/2" Custom Cut Baffle Position

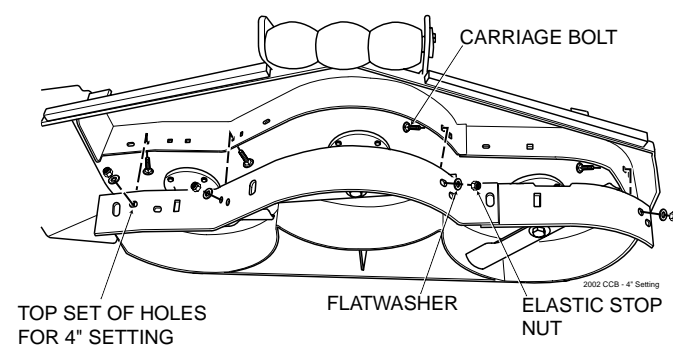

Figure 6-11. 4" Custom Cut Baffle Position

MAINTENANCE

7.1 MAINTENANCE CHART - RECOMMENDED SERVICE INTERVALS

Break-In (First 10)	HOURS					Procedure	Comments
	8	40	100	200	500		
X						Check all hardware for tightness	
X						Check hydraulic oil level	See paragraph 7.3
X						Check all belts for proper alignment	See paragraph 7.8
X (First 5)						Change engine oil and filter	See paragraph 7.4
X						Check hydraulic hoses for leaks	Use extreme caution when checking the hydraulic hoses See paragraph 2.5
X						Check coolant level	See paragraph 7.12
	X					Check engine oil level	See paragraph 7.4
	X					*Clean mower	See paragraph 7.14
	X					Check condition of blades	See paragraph 7.9
	X					Apply grease to fittings	See paragraph 7.2
	X					Check tire pressure	See paragraph 7.10
	X					Check coolant level	See paragraph 7.12
		X				Check battery electrolyte level, clean battery posts and cables	See paragraph 7.7
		X				Check belts for proper alignment	See paragraph 7.8
			X			Apply grease to fittings	See paragraph 7.2
			X			Change engine oil	See paragraph 7.4
			X			*Clean air cleaner element	See paragraph 7.6
			X			Check lubricant in cutter deck gearbox	See paragraph 7.11

* Perform these maintenance procedures more frequently under extreme dusty or dirty conditions

MAINTENANCE CHART - RECOMMENDED SERVICE INTERVALS (CONT'D)

Break-In (First 10)	HOURS					Procedure	Comments
	8	40	100	200	500		
				X		Apply grease to fittings	See paragraph 7.2
				X		Check hardware for tightness	
				X		Change engine oil filter	See paragraph 7.4
				X		Check hydraulic oil level	See paragraph 7.3
					X	Replace engine fuel filter	See paragraph 7.5
					X	Drain hydraulic system and replace hydraulic oil	See paragraph 7.3 Use SAE 20W50 Motor Oil
					X	Replace hydraulic oil filter	See paragraph 7.3
					X	Replace cutter deck gearbox lubricant	See paragraph 7.1
					X	Change coolant	See paragraph 7.12

7.2 LUBRICATION





**GREASE FITTING LUBRICATION CHART
(SEE FIGURE 7-1)**

LOCATION	LUBRICATION INTERVAL	LUBRICANT	NO. OF PLACES
1 Caster Wheel Pivot	500 Hours/Yearly	Chassis Grease	2
2 Caster Wheel Bearings	100 Hours/Bi-Weekly	Chassis Grease	2
3 Brake Actuator	200 Hours/Monthly	Chassis Grease	2
4 Cutter Deck Bellcranks	40 Hours/Weekly	Chassis Grease	4
5 Cutter Deck Pusharms	100 Hours/Bi-Weekly	Chassis Grease	2
6 PTO Spindle	40 Hours/Weekly	+Lithium MP White Grease 2125	1
7 Cutter Deck Spindle	40 Hours/Weekly	+Lithium MP White Grease 2125	3
8 Brake Handle	200 Hours/Monthly	Chassis Grease	1
9 Cutter Deck Drive Shaft U-Joints	200 Hours/Monthly	Chassis Grease	2
10 Cutter Deck Drive Shaft Slip Sleeve	40 Hours/Weekly	Chassis Grease	1

+ Compatible Greases: Mobilix #2 found at Mobil Service Stations
 Ronex MP found at Exxon Service Stations
 Super Lube MEP #2 & Super Stay-M #2 found at Conoco Stations
 Shell Alvania #2 found at Shell Service Stations
 Lidok EP #2 found at industrial shops

GREASE FITTING LUBRICATION

LUBRICANT / INTERVAL

-  LITHIUM MP WHITE GREASE 2125
(40 HOURS / WEEKLY)
-  CHASSIS GREASE
(100 HOURS / BI-MONTHLY)
-  CHASSIS GREASE
(200 HOURS / MONTHLY)
-  CHASSIS GREASE
(500 HOURS / YEARLY)

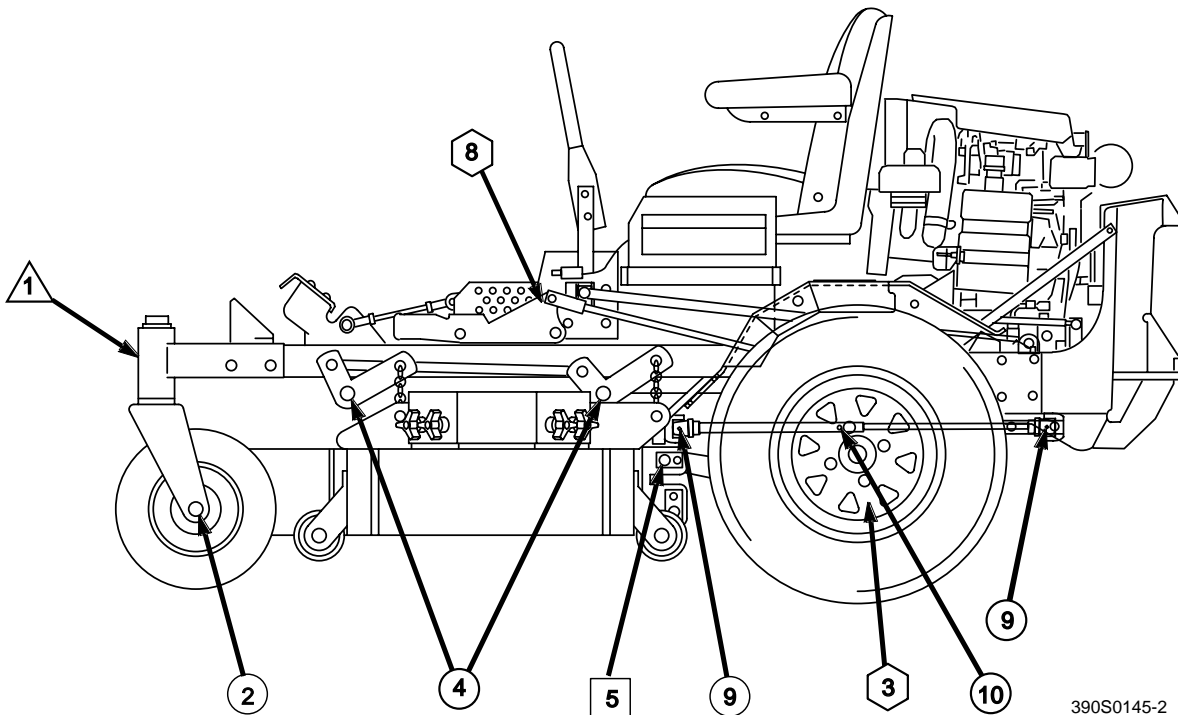
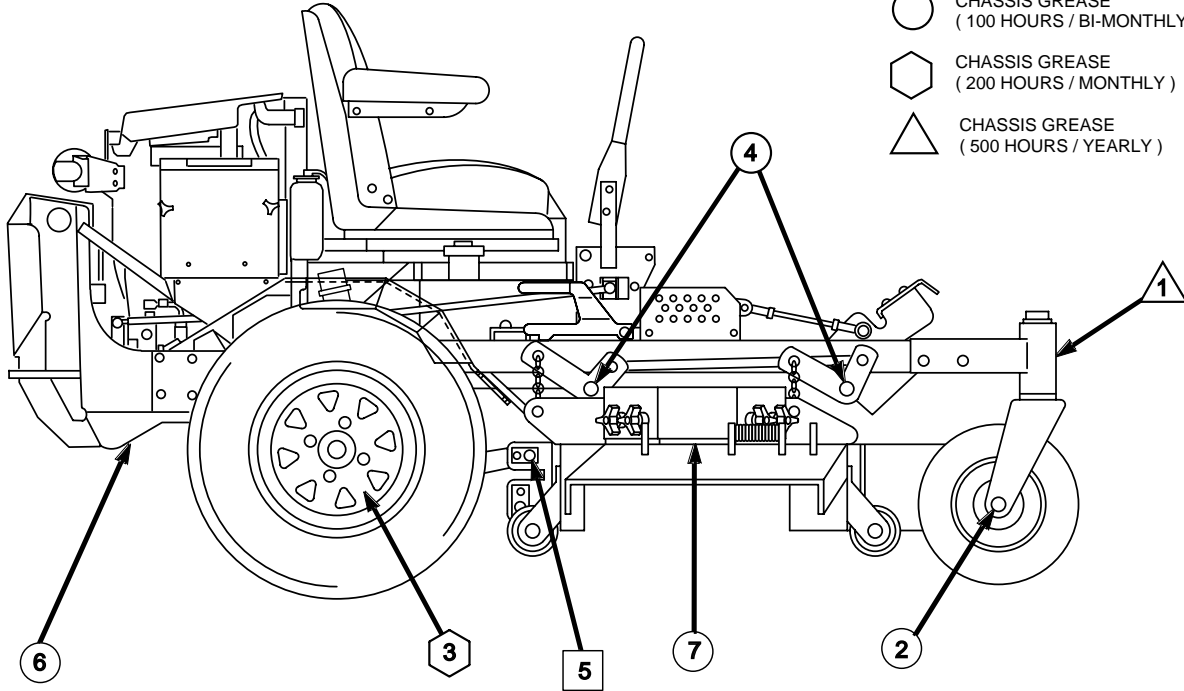

390S0145-2

Figure 7.1 Lubrication Fitting Points

7.3 HYDRAULIC SYSTEM

A. Checking Hydraulic Oil Level

The hydraulic oil level should be checked after the first 10 hours of operation. Thereafter, check the oil after every 200 hours of machine operation or monthly, whichever occurs first.

-IMPORTANT-

If the oil level is consistently low, check for leaks and correct immediately.

1. Wipe dirt and contaminants from around the reservoir cap. Remove the cap from the hydraulic oil reservoir.
2. Visually check the level of hydraulic oil. Hydraulic oil must be at least 3-1/4" inches from top of the filler neck. If the level cannot be determined visually, use a clean tape measure to check the level. If the fluid is low, add 20W50 motor oil. **DO NOT** overfill; (overfilling the oil reservoir may cause oil seepage around the cap area).
3. Clean the fill cap and install it onto the reservoir.

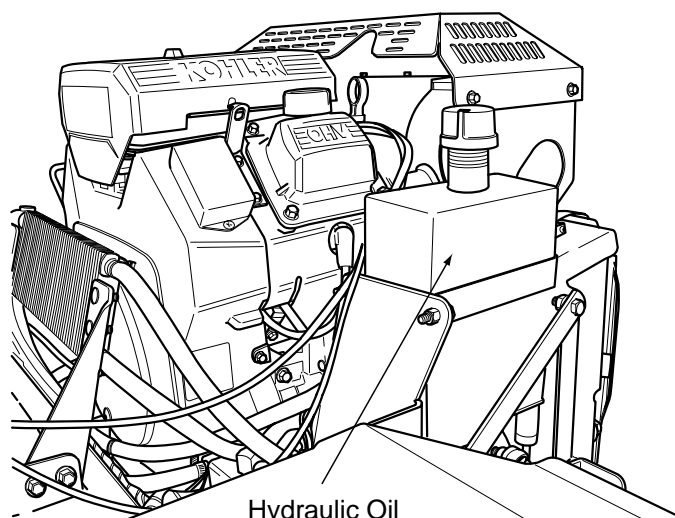

Hydraulic Oil Reservoir

STT99HOR-1

Figure 7-2 Hydraulic Oil Reservoir

B. Changing Hydraulic Oil

The hydraulic oil should be changed after every 500 hours or annually, whichever occurs first. The oil should also be changed if the color of the fluid has become black or milky. A black color and/or a rancid odor usually indicates possible overheating of the oil, and a milky color usually indicates water in the hydraulic oil.

-NOTE-

The hydraulic oil should be changed if you notice the presence of water or a rancid odor to the hydraulic oil.

1. Park the mower on a level surface and stop the engine.
2. Place a suitable container under the hydraulic oil reservoir. Remove the fill cap from the reservoir. Remove the drain plug from the bottom of the reservoir. (See Figure 7-2). Allow the fluid to drain into the container and properly discard it.
3. Re-install the drain plug into the reservoir and be sure it is tight.

-NOTE-

Before refilling the hydraulic oil reservoir the hydraulic oil filter should be changed as outlined in section C on the next page.

4. Fill the reservoir to 3-1/4" inches from the top of the filler neck with 20W50 motor oil.
5. Replace the reservoir fill cap. Start the engine and drive forward and backward for two minutes. Check the oil level in the reservoir. If necessary, add oil to the reservoir.

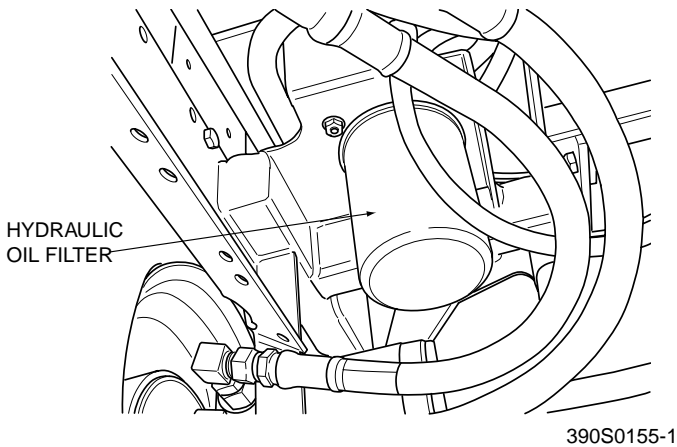

Figure 7-3 Hydraulic Oil Filter

C. Changing Hydraulic Oil Filter Element

The hydraulic oil filter should be changed after every 500 hours of operation or annually, whichever occurs first.

1. Remove the oil filter element (Figure 7-3) and properly discard it. Fill the new filter with clean oil and install the filter. Hand tighten only.
2. Run the engine at idle speed with the speed control lever in neutral for five minutes.
3. Check the oil level in the hydraulic tank. It must be 3-1/4" inches from the top of the filler neck. If necessary, add SAE 20W50 motor oil.

7.4 ENGINE OIL

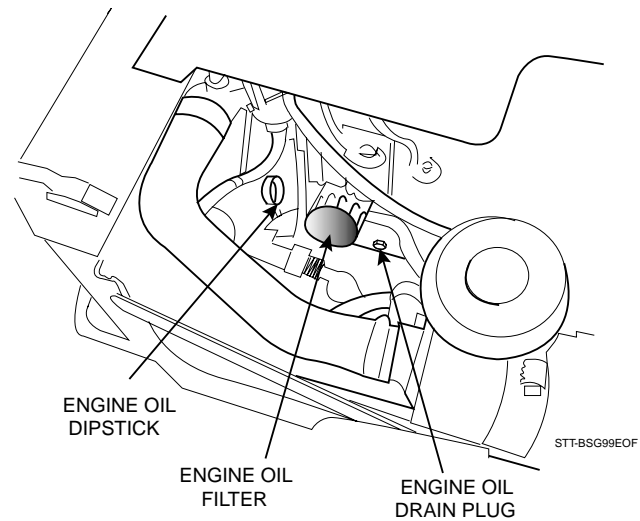

Figure 7-4 Engine Dipstick, Filter, Oil Drain

A. Checking Engine Crankcase Oil Level

The engine oil level should be checked after every 8 hours of operation or daily as instructed in the Engine Operator's Manual furnished with this mower (See Figure 7-4).

B. Changing Engine Crankcase Oil

After the first 5 hours of operation, change the engine crankcase oil and replace the oil filter. Thereafter, change the engine crankcase oil after every 100 hours of operation or bi-weekly, whichever occurs first. Refer to the Engine Operator's Manual furnished with this mower for instructions (See Figure 7-4).

C. Changing Engine Oil Filter

After the first 5 hours of operation, replace the engine oil filter. Thereafter, replace the oil filter after every 200 hours of operation or every month, whichever occurs first. Refer to Engine Operator's Manual for instructions (See Figure 7-4).

Section 7

7.5 ENGINE FUEL SYSTEM

! DANGER:

To avoid injury from burns, allow the mower to cool before removing the fuel tank cap and refueling.

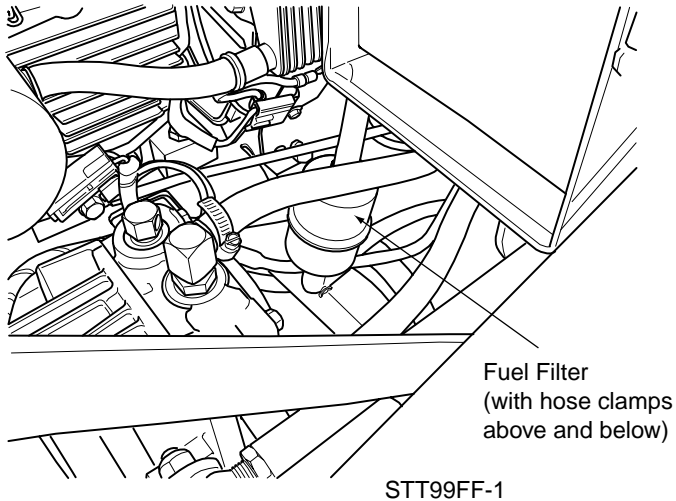

Figure 7-5 Fuel Filter

A. Filling the Fuel Tank

Fill the fuel tank at the beginning of each operating day to within 1 inch below the filler neck. Do not overfill. Use clean, fresh unleaded gasoline with a minimum octane rating of 87.

B. Replacing In-Line Fuel Filter Element

-NOTE-

The fuel filter is located below the hydraulic tank. Figure 7-5 is for illustration purposes only.

The in-line fuel filter (Figure 7-5) should be replaced after every 500 hours of operation or annually, whichever occurs first.

1. Close the shut-off valve. Remove the two clamps securing the fuel filter to the fuel hose. Remove the fuel filter.

2. Install a new fuel filter. Be sure it is installed in the proper direction. Secure to the fuel hose using the two clamps.

7.6 ENGINE AIR CLEANER

A. Cleaning and/or Replacing Air Cleaner Element

For any air cleaner, the operating environment dictates the air cleaner service periods. To make it convenient for you we have installed an "Air Cleaner Indicator" which is located just behind the air filter. The indicator window will turn red when it is time to service the air filter. Do not service the filter unless this indicator is red.

-NOTE-

In extremely dusty conditions it may be necessary to check the indicator daily to prevent engine damage.

1. Snap open the two clips securing the air cleaner cover to the air cleaner box. Remove the air cleaner cover, clean the duck bill vent of any dust and set the cover aside.
2. Remove the air cleaner element and inspect.
3. Clean or replace the element as recommended by the engine manufacturer.
4. Replace the air filter cover and be sure to snap closed the two clips.
5. Reset the air cleaner indicator by pushing the button on the end of the indicator. The indicator window should return to clear.

7.7 BATTERY

A. Checking Electrolyte Level and Cleaning Battery

After every 40 hours of operation or weekly, whichever occurs first, check the electrolyte level in the battery and clean the battery and connections. Dirt and fluid on the top of the battery can cause the battery to discharge. Corrosion of the battery terminals or loose connections will cause poor battery performance.

⚠️ WARNING:

Lead-acid batteries produce flammable and explosive gases. To avoid personal injury when checking, testing or charging batteries, **DO NOT** use smoking materials near batteries. Keep arcs, sparks and flames away from batteries. Provide proper ventilation and wear safety glasses.

⚠️ WARNING:

Battery posts, terminals, and related accessories contain lead and lead compounds, chemicals known to the State of California to cause cancer and reproductive harm. Wash hands after handling.

1. Loosen the two plastic wing nuts and then remove the battery cover.
2. Remove the battery cell caps. Visually inspect electrolyte level in the cells. If electrolyte is below the bottom of vent well, fill with clean distilled water to the bottom of vent wells (1/4 to 1/2 inch above the plates). Install the battery cell caps.

-IMPORTANT-

Do not overfill the battery. Electrolyte will overflow through the vent tube onto parts of the machine, resulting in severe corrosion.

3. Clean the cable ends and battery posts with steel wool. Use a solution of baking soda and water to clean the battery. Do not allow the solution to enter the battery cells.
4. Tighten the cable connections securely and apply a light coat of silicone dielectric grease to the terminal connections to prevent corrosion.
5. Install the battery cover.

⚠️ WARNING:

Electric storage battery fluid contains sulfuric acid which is **POISON** and can cause **SEVERE CHEMICAL BURNS**. Avoid contact of fluid with eyes, skin, or clothing. Use proper protective gear when handling batteries. **DO NOT** tip any battery beyond 45° angle in any direction. If fluid contact does occur, follow first aid suggestions below.

BATTERY ELECTROLYTE FIRST AID

EXTERNAL CONTACT — Flush with water.

EYES — Flush with water for at least 15 minutes and get medical attention immediately.

INTERNAL — Drink large quantities of water. Follow with Milk Of Magnesia, beaten egg, or vegetable oil. Get medical attention immediately. In case of internal contact, **DO NOT** give fluids that would induce vomiting.

B. Charging the Battery

Refer to the battery charger’s manual for specific instructions.

Under normal conditions the engine’s alternator will have no problem keeping a charge on the battery. If the battery has been completely discharged for a long period of time, the alternator may not be able to recharge the battery, and a battery charger will be required.

DO NOT charge a frozen battery. It may explode and cause injury. Let the battery warm before attaching a charger.

Whenever possible, remove the battery from the mower before charging and make sure the electrolyte covers the plates in all cells.

Section 7

WARNING:

BATTERIES PRODUCE EXPLOSIVE GASES. Charge the battery in a well ventilated space so gases produced while charging can dissipate.

Charging rates between 3 and 50 amperes are satisfactory if excessive gassing or spewing of electrolyte does not occur or the battery does not feel excessively hot (over 125°F). If spewing or gassing occurs or the temperature exceeds 125°F, the charging rate must be reduced or temporarily stopped to permit cooling.

C. Jump Starting

1. The booster battery must be a 12 volt type. If a vehicle is used for jump starting, it must have a negative ground system.
2. When connecting the jumper cables, connect the positive cable to the positive battery post, then connect the negative cable to the negative battery post.

7.8 DRIVE BELTS

All drive belts are spring loaded and self-tensioning, however after the first 2, 4, 8 and 10 hours of operation, the belts should be checked for proper alignment and wear. Thereafter, check the belts after every 40 hours of operation or weekly, whichever occurs first.

-NOTE-

If you experience frequent belt wear or breakage, see your authorized Scag service center for belt adjustment.

7.9 CUTTER BLADES

A. Blade Inspection

1. Remove the ignition key before servicing the blades.
2. Raise the mower deck to the highest position. Place the lanyard pin in the highest cutting height position to prevent the cutter deck from falling.

WARNING:

Always wear proper hand and eye protection when working with cutter blades.

3. Check the cutter blades for straightness. If the cutter blades appear bent, they will need to be replaced.

WARNING:

Do not attempt to straighten a bent blade, and never weld a broken or cracked blade. Always replace it with a new blade to assure safety.

4. If a blade cutting edge is dull or nicked, it should be sharpened. Remove the blades for sharpening. See "Blade Replacement."

-NOTE-

Keep the blades sharp. Cutting with dull blades not only yields a poor mowing job, but slows the cutting speed of the mower and causes extra wear on the engine and the blade drive by pulling hard.

B. Blade Sharpening

-NOTE-

If possible, use a file to sharpen the blade. Using a wheel grinder may burn the blade.

-NOTE-

DO NOT sharpen the blades beyond 1/3 of the width of the blade. See Figure 7-9, Page 34.

1. Sharpen the cutting edge at the same bevel as the original. See Figure 7-9, Page 34. Sharpen only the top of the cutting edge to maintain sharpness.

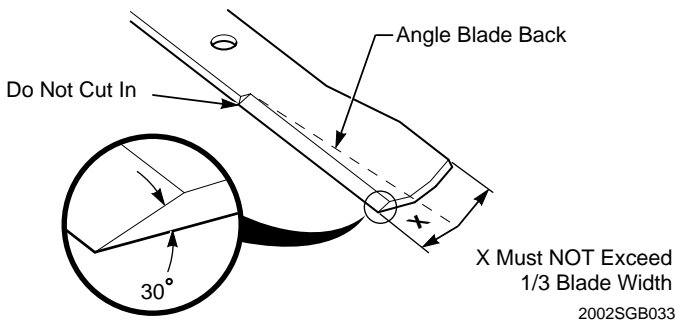

Figure 7-9 Blade Sharpening

2. Check the balance of the blade. If the blades are out of balance, vibration and premature wear can occur. See your authorized Scag dealer for blade balancing or special tools, if you choose to balance your own blades.

C. Blade Replacement



WARNING:

Always wear proper hand and eye protection when working with cutter blades.

1. Remove the ignition key before replacing the blades.
2. Raise the mower deck to the highest position. Place the lanyard pin in the highest cutting height position to prevent the cutter deck from falling.
3. Secure the cutter blades to prevent them from rotating. (Use the optional Blade Buddy tool, P/N 9212, to assist in securing the cutter blades), remove the nut from the blade attaching bolt. Remove the cutter blade, bolt and spacer from the spindle shaft. (Figure 7-10).

-NOTE-

The front of the machine will have to be raised slightly to remove the blade bolt from the cutter spindle.

4. To install the new cutter blade, put the flat washer onto the blade bolt and slide the bolt into the hole in the cutter blade.

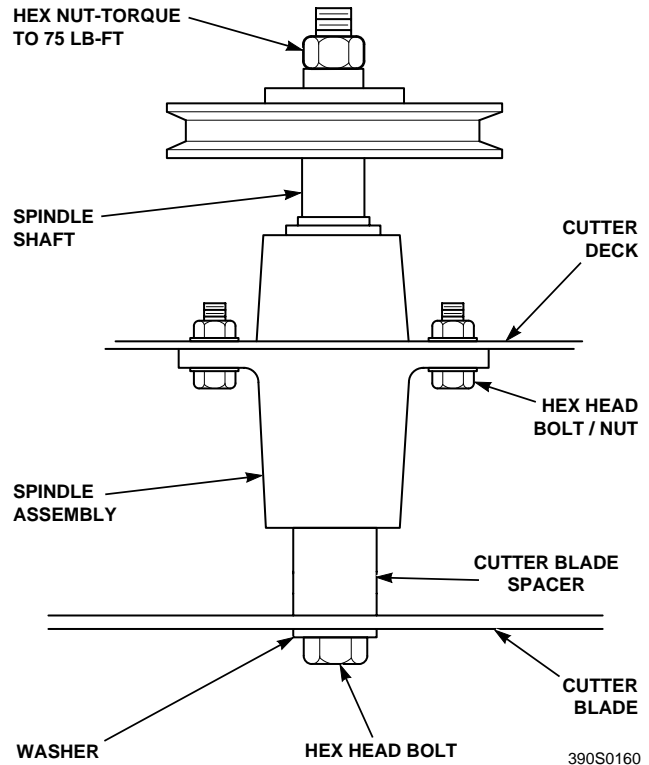

Figure 7-10 Blade Replacement

-NOTE-

Be sure that the blade is installed with the lift wing toward the top.

5. Install the spacer onto the blade bolt and insert the bolt into the cutter spindle.
6. Install the hex nut to the blade bolt at the top of the cutter spindle. Secure the blades from rotating and torque to 75 ft-lbs. (See Figure 7-10)

7.10 TIRES

Check the tire pressures after every 8 hours of operation or daily.

Caster Wheels	25 PSI
Drive Wheels	12 PSI

Section 7

7.11 CUTTER DECK GEARBOX

A. Checking Lubricant Level

CAUTION:

The cutter deck gearbox can reach high operating temperatures. Allow the cutter deck gearbox to cool before servicing.

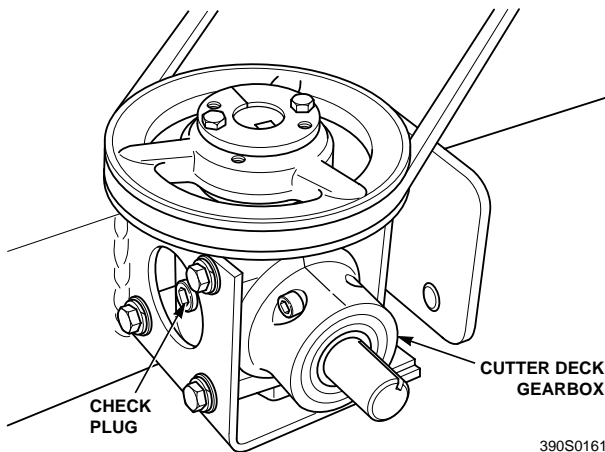

Figure 7-12 Cutter Deck Gearbox

The fluid level in the cutter deck gearbox (Figure 7-12) should be checked after every 100 hours of operation or bi-weekly, whichever occurs first.

1. Lower the cutter deck to its lowest position to gain access to the cutter deck gearbox.
2. Clean and remove the check plug from the side of the gearbox (See Figure 7-12). Visually check that the lubricant level is up to the bottom edge of the check plug hole. If lubricant is low, add SAE 80W90 lubricant through the check plug hole in the gearbox until it is level with the bottom of the check plug hole. Install the check plug and tighten securely.

B. Changing Lubricant

The lubricant in the cutter deck gearbox should be changed after every 500 hours of operation or yearly, whichever occurs first.

1. Place a suitable container beneath the cutter deck gearbox and locate the gearbox drain plug.

2. Remove the drain plug and drain the lubricant into the container and properly discard it.
3. Re-install the drain plug and add EP-80/90 lubricant through the check plug hole in the gearbox until it is level with the bottom of the check plug hole. Install the check plug and tighten securely.

7.12 COOLING SYSTEM

WARNING:

To avoid burns, always allow the engine to cool before removing the radiator cap.

A. Checking Coolant Level

The coolant level should be checked before each day of operation.

1. Remove the radiator cap by turning it slowly counterclockwise to the first stop and allow any pressure to be released. Push down on the cap and turn counterclockwise to remove.
2. Visually check the coolant level. The coolant level should be up to the bottom of the filler neck as shown in figure 7-13. Add a mixture of coolant and soft water as needed.

-NOTE-

Refer to the coolant manufacturer's instructions for the proper coolant mixture ratio.

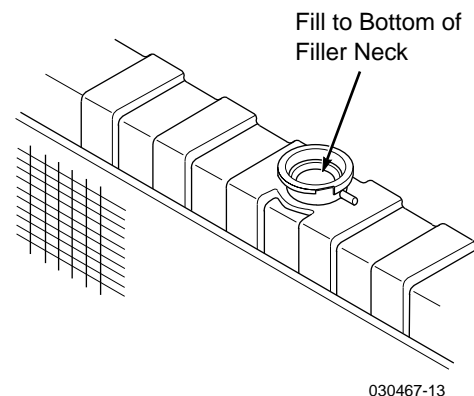

Figure 7-13 Coolant Level in Radiator

3. Replace the radiator cap. Push down on the cap and turn clockwise until it stops.

-NOTE-

The cooling system should be flushed and the coolant replaced every 500 hours of operation or annually. See your Scag dealer for proper coolant replacement.

B. Cleaning the Radiator Debris Screen

After each day of operation, remove and clean the radiator debris screen.



CAUTION:

To avoid personal injury, always wear safety glasses when using compressed air.

1. Pull the debris screen up to remove.
2. Clean the debris screen with compressed air or a water hose.

-NOTE-

Check the radiator for excessive debris and clean with compressed air. Never spray a hot engine with water, use only compressed air to remove debris.

3. Re-install the debris screen to the radiator.

C. Checking The Fan Belt Tension

Periodically check the fan belt tension. The belt should deflect 1/2" with 10 pounds of pressure. See your Scag dealer if the belt is in need of adjustment or replacement.

7.13 BODY, DECK, AND UPHOLSTERY



CAUTION:

Do not wash any portion of the equipment while it is hot. Do not wash the engine; use compressed air.

1. After each use, wash the mower and cutter deck. Use cold water and automotive cleaners. Do not use pressure cleaners.
2. Do not spray electrical components.
3. Use a mild soap solution or a vinyl/rubber cleaner to clean the seat.
4. Repair damaged metal surfaces using Scag touch-up paint available from your authorized Scag dealer. Wax the mower for maximum paint protection.

NOTES

61A, 72A CUTTER DECKS

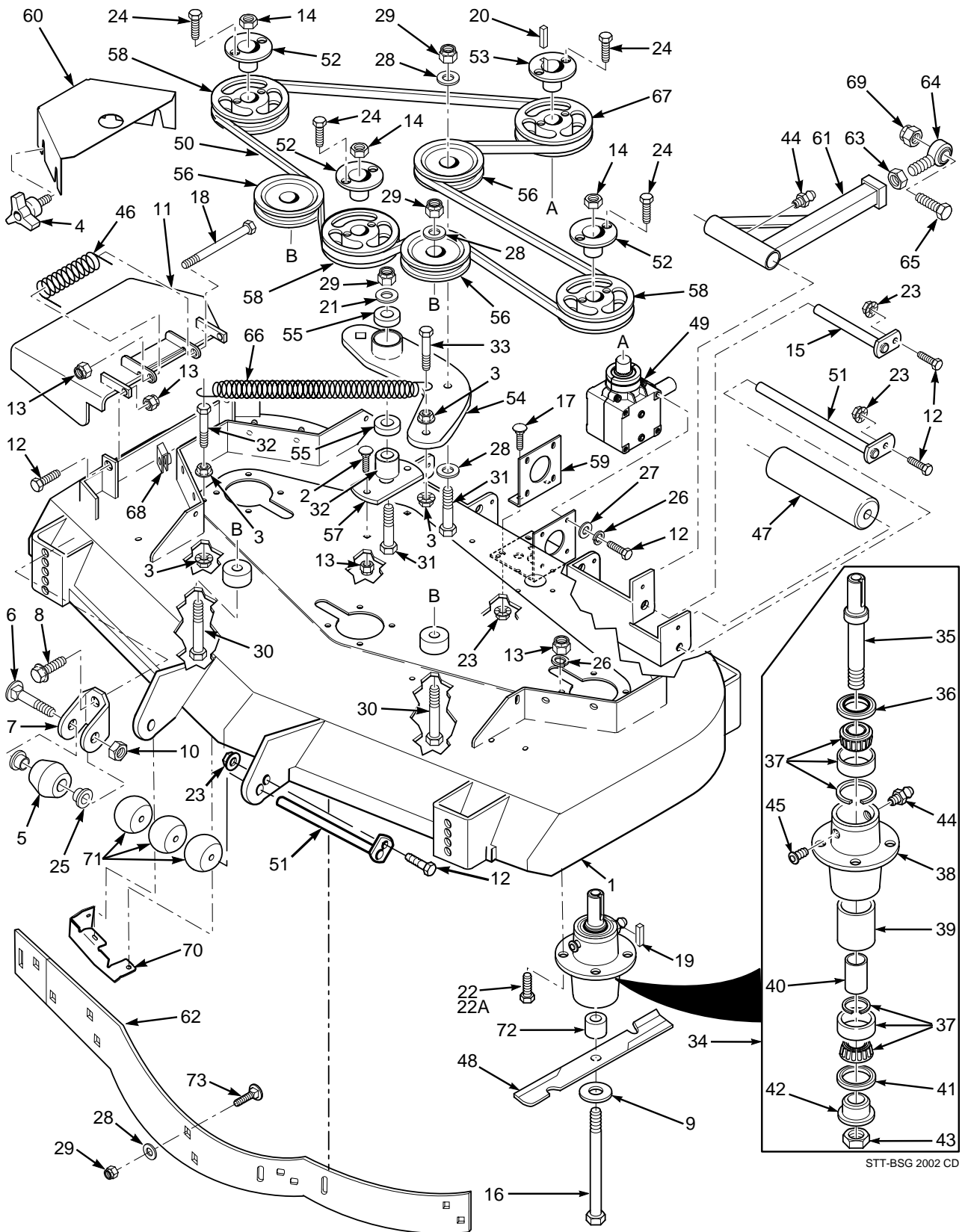

STT-BSG 2002 CD

61A, 72A CUTTER DECKS

Ref. Part No. No.	Description	Ref. Part No. No.	Description		
1	461505	Cutter Deck, 61" Advantage (Includes Decals)	42	43297	Spindle Bushing, Bottom
1	461507	Cutter Deck, 72" Advantage (Includes Decals)	43	481035	Nut, Special 1 - 1/16-18
2	04003-04	Bolt, Carriage 5/16-18 x 1"	44	48114-04	Grease Fitting
3	04019-04	Nut, Hex Serrated Flange 3/8-16	45	48677	Relief Fitting, Tapered Spindle
4	481625-01	Wing nut, 3/8-16	46	482245	Spring, Discharge Chute
5	481632	Anti-Scalp Wheel	47	48038	Guide, Roller
6	04003-26	Bolt, Carriage 3/8-16 x 4"	48	482001	Cutter Blade, 21.0" 61"
7	422478	Anti-Scalp Wheel Bracket	48	482002	Cutter Blade, 24.5" 72"
8	04017-27	Bolt, Hex Serrated Flange 3/8-16 x 1"	49	482486	Gearbox Assembly, Deck Drive
9	04043-06	Flatwasher, 5/8" (.688 x 1.75 x .134)	50	481558	Belt, Cutter Deck Drive, 61"
10	04021-05	Locknut, 3/8-16 Center Lock	50	481980	Belt, Cutter Deck Drive, 72"
11	461296	Discharge Chute, 61" & 72" Adv.	51	45944	Roller Shaft
12	04001-12	Bolt, Hex Head 5/16-18 x 1.75" (Front)	52	48926	Tapered Hub, 1-1/8" Bore
	04001.11	Bolt, Hex Head 5/16-18 x 1.50" (Rear)	53	48141	Tapered Hub, 1" Bore
13	04021-10	Nut, Hex Elastic Stop 5/16-18	54	461174	Idler Arm, Cutter Deck
14	04020-09	Nut, 5/8-11 UNC	55	48224	Bearings, Ball
15	451240	Push Arm Shaft	56	482416	Pulley, Idler
16	04001-41	Bolt, Hex Head 5/8-11 x 9.50"	57	422713	Base, Idler Pivot
17	04003-12	Bolt, Carriage 5/16-18 x .75"	58	48753	Pulley, 6.35 O.D. - 61"
18	04001-154	Bolt, Hex Head 5/16-18 x 4.75"		48967	Pulley, 6.95 O.D. - 72"
19	04063-08	Key, 1/4 x 1/4 x 2"	59	422426	Mounting Plate, Gearbox
20	04063-01	Key, 1/4 x 1/4 x 1.25"	60	422413	Belt Cover, LH - 61"
21	04043-04	Flatwasher, 3/8-.39 x .938 x .105 HD		422677	Belt Cover, LH - 72"
22	04001-11	Bolt, Hex Head 5/16-18 x 1.50"		422413	Belt Cover, RH - 61"
22A	04001-12	Bolt, Hex Head 5/16-18 x 1.75"		422708	Belt Cover, RH - 72"
23	04021-10	Nut, Hex Serrated Flange 5/16-18	61	461516	Pusharm (includes items 44, 63 & 64)
24	04001-01	Bolt, Hex Head 1/2-20 x .75"	62	451509	Baffle, Custom Cut 61A
25	48100-15	Bushing, .376 I.D. Oilite		451510	Baffle, Custom Cut 72A
26	04030-03	Lockwasher, 5/16"	63	04020-16	Nut, Hex Head 5/8-18 UNF
27	04040-15	Flatwasher, 5/16" (.375 x .875 x .083)	64	48763	Rod End, 5/8" Male RH Thread
28	04041-07	Flatwasher, 3/8" (.391 x .938 x .105)	65	04001-79	Bolt, Hex Head 5/8-11 x 4-1/2"
29	04021-09	Nut, Hex Elastic Stop 3/8-16	66	481597	Spring, Cutter Deck
30	04001-62	Bolt, Hex Head 3/8-16 x 3.25"	67	482480	Pulley, 6.75 O.D. - 61"
31	04001-31	Bolt, Hex Head 3/8-16 x 2.50"		48753	Pulley, 6.35 O.D. - 72"
32	43503	Pivot, Idler - Short	68	04110-03	U-Nut, 3/8-16
33	04001-136	Bolt, Hex Head 3/8-16 x 1.50" Grade 8	69	04021-13	Nut, Hex Elastic Stop 5/8-11
34	46631	Spindle Assembly	70	422601	Discharge Baffle 61"
35	43589	Spindle Shaft		422602	Discharge Baffle 72"
36	481024	Seal, Top	71	482295	Guide Roller
37	481022	Bearing Assembly	72	43590	Spacer, Spindle
38	43294	Spindle Housing	73	04003-23	Bolt, Carriage 3/8-16 x 1"
39	43312	Spacer, Outside			
40	43296	Spacer, Inside			
41	481025	Seal, Bottom			

* Common hardware which should be purchased locally. All bolts Grade 5 plated, all other fasteners zinc plated.

CUTTER DECK CONTROLS

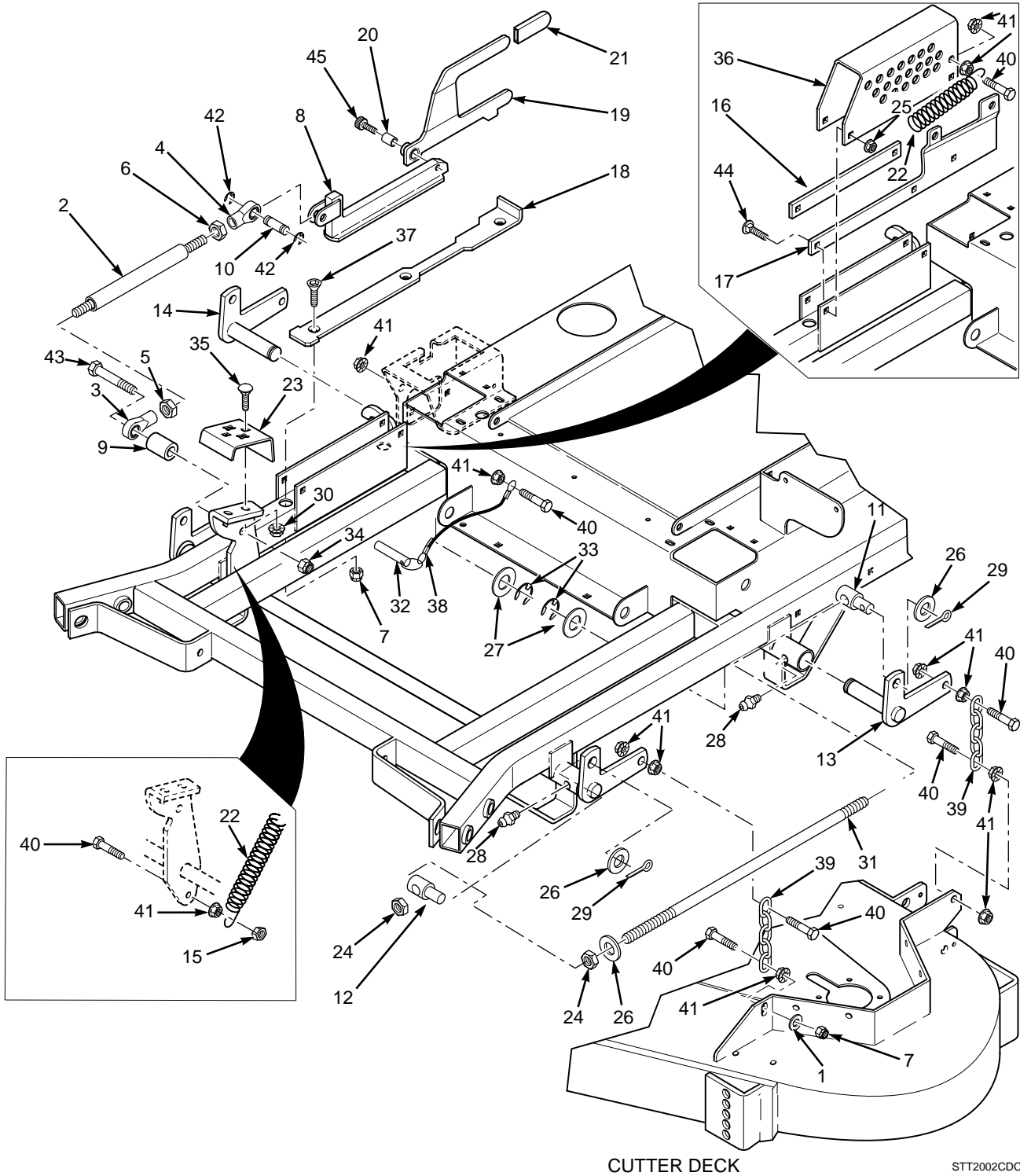

CUTTER DECK CONTROLS

Ref. No.	Part No.	Description
1	04041-07	Flatwasher, 3/8"
2	481764	Link, Deck Lift
3	481765	Rod End, Female - 1/2-20 RH
4	481766	Rod End, Female - 1/2-20 LH
5	04020-27	Nut, Jam 1/2-20 RH
6	04020-28	Nut, Jam 1/2-20 LH
7	04021-09	Nut, 3/8-16 Elastic Stop
8	482429	Slide Weldment, Height Adjustment
9	43391	Spacer, Decklift Pedal
10	43487	Pin, Decklift
11	43526	Swivel Joint, LH
12	43527	Swivel Joint, RH
13	45904	Bellcrank Weldment, LH Rear
14	45905	Bellcrank Weldment, RH Rear
15	04021-05	Locknut, 3/8-16 Center Lock
16	422381	Guide, Short
17	423509	Guide, Long
18	422346	Lockplate, Decklift
19	46975	Deck Latch (Includes items 20& 21)
20	48100-14	Bushing, .502 ID.
21	481428	Grip, Deck Latch
22	481598	Spring, Helper (61" & 72" Cutter Decks Only)
23	422451	Foot Pedal, Height Adjustment
24	04020-09	Nut, Hex 5/8-11
25	04019 -03	Nut, Hex Serrated Flange 5/16-18
26	04040-09	Flatwasher, 5/8" (.656 x 1.312 x .095)
27	04041-14	Flatwasher, 1" (1.062 x 1.50 x .048)
28	48114-04	Grease Fitting
29	04061-07	Cotter Pin, 3/16 x 1"
30	04021-10	Nut, Hex Elastic Stop 5/16-18
31	04004-44	Stud, 5/8-11 x 22.0"
32	04067-05	Ring Pin, 1/2 x 3.30"
33	04050-08	Ring, Retaining 1" External "E"
34	04021-07	Nut, Hex Elastic Stop 1/2-13
35	04003-11	Bolt, Carriage 3/8-16 x 1-1/4"
36	423463	Bracket, Cutting Height Adjustment
37	04014-03	Screw, Cap 5/16-18 x 3" FHHS
38	481547	Lanyard, Deck Height Pin
39	48540	Chain
40	04001-20	Bolt, Hex Head 3/8-16 x 1-1/2"
41	04019-04	Nut, Hex Serrated Flange 3/8-16
42	04050-10	Ring, Retaining 1/2" External "E"
43	04001-74	Bolt, Hex Head 1/2-13 x 3"
44	04003-04	Bolt, Carriage 5/16-18 x 1"
45	04009-02	Bolt, Shoulder 1/2 x 3/4"

* Common hardware which should be purchased locally. All bolts Grade 5 plated, all other fasteners zinc plated.

SHEET METAL COMPONENTS

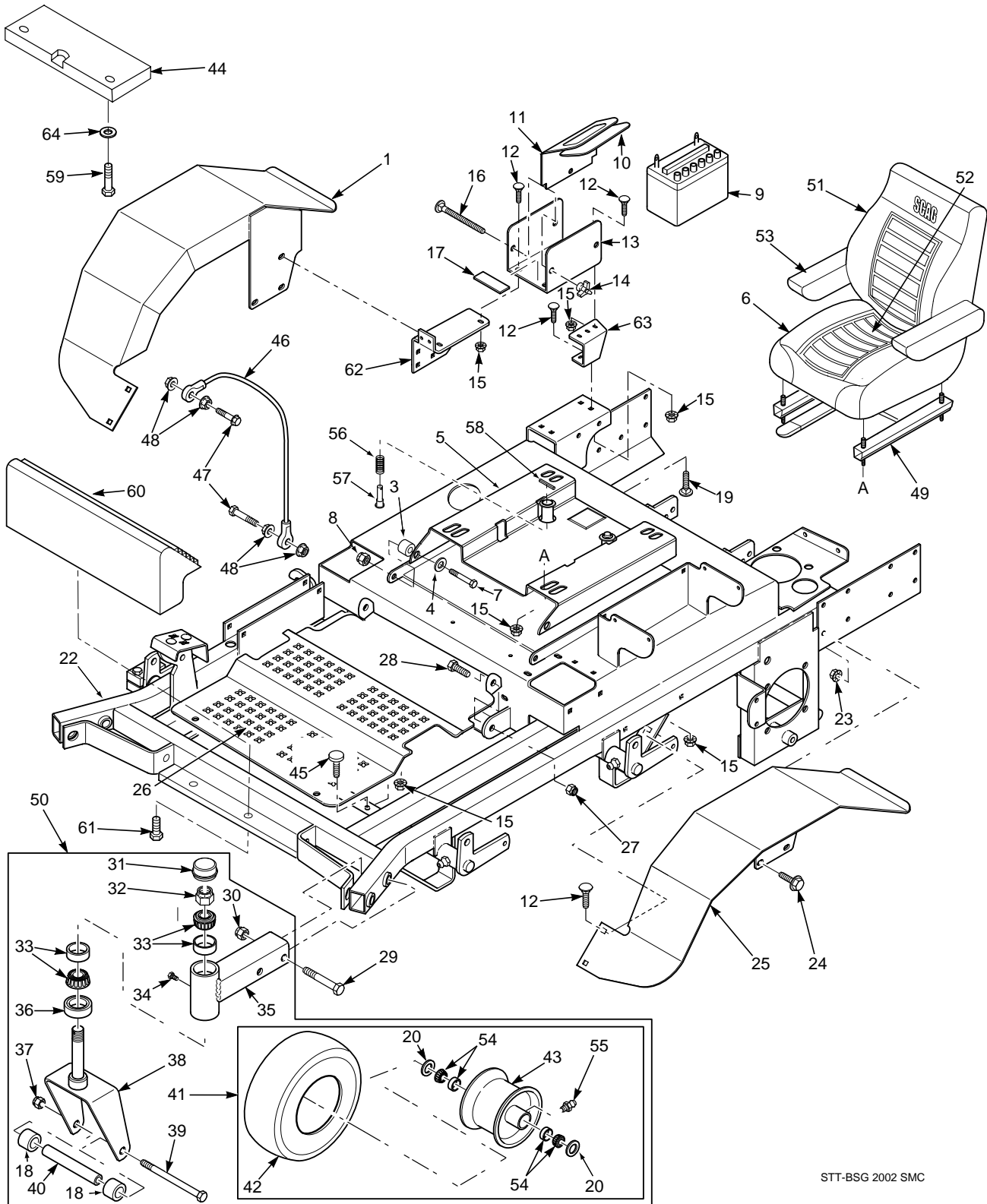

STT-BSG 2002 SMC

SHEET METAL COMPONENTS

Ref. No.	Part No.	Description	Ref. No.	Part No.	Description
1	451481	Fender Weldment, RH	38	451416	Yoke Weldment, Caster (61A & 72A)
2	04001-09	Bolt, Hex Head, 5/16-18 x 1, Zinc	39	04001-134	Bolt, Hex Head 1/2-13 x 7-1/2" (52A)
3	43606	Spacer		04001-167	Bolt, Hex Head 1/2-13 x 9-1/2" (61A & 72A)
4	04041-07	Flatwasher, 3/8-.391 x .938 x .105	40	43581	Sleeve, Caster Wheel (52A)
5	451448	Seat Plate Weldment		43583	Sleeve, Caster Wheel (61A, 72A)
6	482597	Seat Assembly w/armrest	41	482504	Wheel Assy (Inc.items 20, 42, 43, 54, 55)
7	04001-45	Bolt, Hex Head 3/8-16 x 2.0"	42	481613	Tire, 13 x 5.00 4-Ply (52A)
8	04021-09	Nut, Elastic Stop 3/8-16		482619	Tire, 13 x 6.50 4-Ply (61A, 72A)
9	482283	Battery (Not Avail. through Scag)	43	482625	Rim Assembly, 52A (Includes item 55)
10	481780	Pad, Battery Cover		482620	Rim Assembly, 61A & 72A (Inc. item 55)
11	422682	Cover, Battery	44	41020	Weight (61" cutter deck only)
12	04003-12	Bolt, Carriage 5/16-18 x 3/4"	45	481284	Bumper, Rubber
13	423425	Plate, Battery Box	46	48566	Cable, Seat Stop
14	04029-01	Wing Nut, 1/4-20 x 3/4"	47	04001-59	Bolt, Hex Head 1/4-20 x 1-1/4"
15	04019-03	Nut, Hex Serrated Flange 5/16-18	48	04019-02	Nut, Hex Serrated Flange 1/4-20
16	04003-30	Bolt, Carriage 1/4-20 x 6"	49	482502	Seat Adjustment, Track Set
17	48661	Rubber Pad	50	461447	Caster Wheel Assy (Inc. 31 thru 43)
18	43584	Spacer, Caster Wheel			61A (LH)
19	04003-04	Bolt, Carriage 5/16-18 x 1"		461448	Caster Wheel Assy (Inc. 31 thru 43)
20	482622	Seal			61A (RH)
21	04021-09	Lock Nut, 3/8-16, Elast. Stop		461449	Caster Wheel Assy (Inc. 31 thru 43)
22	461524	Main Frame			72A (LH)
23	04019-04	Nut, Hex Serrated Flange 3/8-16		461450	Caster Wheel Assy (Inc. 31 thru 43)
24	04017-27	Screw, Hex Serrated Flange 3/8-16 x 1"			72A (RH)
25	451480	Fender Weldment, LH	51	482614	Back Cushion Cover
26	423489	Foot Plate	52	482615	Seat Cushion Cover
27	04021-09	Nut, Hex Elastic Stop 3/8-16	53	482618	Arm Rest, Right Hand
28	04001-19	Bolt, Hex Head 3/8-16 x 1"		482617	Arm Rest, Left Hand
29	04001-125	Bolt, Hex Head 5/8-11 x 4"		482616	Arm Rest Cover
30	04021-13	Nut, Hex Elastic Stop 5/8-11	54	482621	Bearing w/ Race
31	481559	Cap, Grease	55	48114-07	Grease Fitting
32	04021-20	Nut, Hex Elastic Stop 1.0-14	56	481389	Spring, Seat
33	481657	Bearing W/Race	57	43462	Pin Retainer, Spring
34	482028-01	Plug, 1/4-28 THD Form	58	04060-01	Roll Pin, Spring 5/32 x 3/4"
35	451449	Extention Weldment, Caster 52A (LH)	59	04001-145	Bolt, Hex Head 1/2-13 x 3.5"
	451450	Extention Weldment, Caster 52A (RH) & 61A (LH)	60	481825	Footrest
	451451	Extention Weldment, Caster 61A (RH)	61	04001-71	Bolt, Hex Head 1/2-13 x 1.5"
	451452	Extention Weldment, Caster 72A (LH)	62	423419	Mounting Bracket, Battery
	451453	Extention Weldment, Caster 72A (RH)	63	423624	Support Bracket, Battery Box
36	481025	Seal, 2.00 OD. x 1.625 Bore	64	04040-13	Flat Washer 1/2-.562 x .1.375 x .109
37	04021-07	Nut, Hex Elastic Stop 1/2-13			

* Common hardware which should be purchased locally. All bolts Grade 5 plated, all other fasteners zinc plated.

DECK DRIVE COMPONENTS

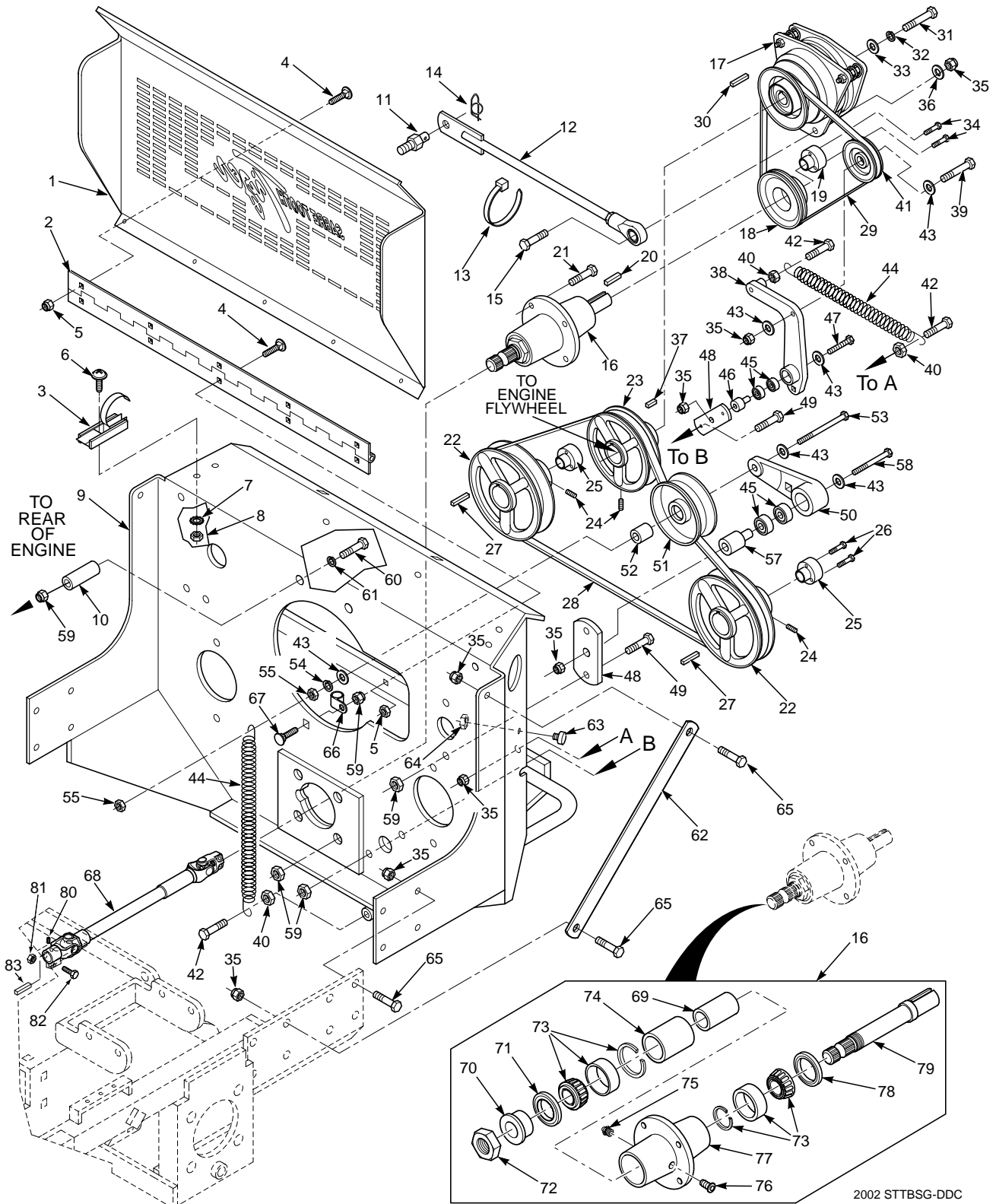

2002 STTBSG-DDC

DECK DRIVE COMPONENTS

Ref. Part No. No.	Description	Ref. Part No. No.	Description		
1	422845	Belt Guard, Rear	53	04001-138	Bolt, Hex Head 3/8-16 x 3.75" Grade 8
2	481531	Hinge, Rear Belt Guard	54	04030-04	Lock Washer 3/8" .638 x .380 x .094"
3	481309	Latch, Hood	55	04020-04	Nut 3/8-16
4	04003-07	Carr. Bolt 1/4-20 x .5"	56	04021-05	Nut, Elastic 3/8-16
5	04019-02	Nut, Serr. Flg. 1/4-20	57	43504	Pivot, Idler - Long
6	04010-01	Screw, #10-32 x .5, Phillips Head	58	04001-54	Bolt, Hex Head 3/8-16 x 3.00"
7	04031-01	Lock Washer, #10	59	04021-10	Nut, Elastic 5/16-18
8	04020-01	Nut, #10-32	60	04001-49	Bolt, Hex Head 5/16-18 x 3.00"
9	451457	Weldment, Pump Mounting	61	04030-03	Lock Washer 5/16"
10	43506	Spacer, Engine	62	422684	Brace, Engine Mounting Plate
11	43507	Stud, Anti-Rotation	63	481284	Bumper, Rubber
12	482433	Linkage Assembly, Anti-Rotation	64	04019-03	Nut, Serr. Flg. 5/16-18
13	48028-05	Tie, Cable	65	04001-19	Bolt, Hex Head 3/8-16 x 1.00"
14	04069-01	Pin, Rue	66	48030-09	Clamp, Wire
15	04001-20	Bolt, Hex Head 3/8-16 x 1.50"	67	04003-12	Bolt, Carr. 5/16-18 x .75"
16	46977	Spindle Assembly, Deck Drive	68	482438	Driveshaft
17	461467	Clutch, Electric PTO	69	43296	Spacer, Inside
18	481398	Pulley, 6.35" dia. Tapered Bore	70	43297	Bushing
19	481536	Hub, Tapered 1" dia.	71	481025	Seal, 2.00 OD x 1.625 Bore
20	04063-06	Key, 1/4 x 1/4 x 1.5"	72	481035	Nut, 1.06-18
21	04001-10	Bolt, Hex Head 5/16-18 x 1.25"	73	481022	Roller Bearing Assembly
22	481883	Pulley, 6.25" OD, Tapered	74	43312	Spacer, Outside
23	481788	Pulley, 5.45" OD	75	48114-04	Grease Fitting 1/4-28 Self Tapping
24	04012-04	Set Screw, 5/16-18 x .375"	76	48677	Relief Fitting
25	481884	Hub, Tapered 17mm Bore	77	43294	Spindle Housing
26	04001-01	Bolt, Hex Head 1/4-20 x .75"	78	481024	Seal, 2.00 OD x 1.5 Bore
27	04063-27	Key, 5mm x 5mm x 30mm	79	43534	Shaft, Spindle
28	481461	Belt, Pump Drive	80	04012-08	Screw, Set 3/8-16 x 3/8"
29	481460	Belt, Deck Drive	81	04021-05	Nut, Center Lock 3/8-16
30	04063-11	Key, 1/4 x 1/4 x 2.5"	82	04001-21	Bolt, Hex Head 3/8-16 x 1-3/4"
31	04001-101	Bolt, Hex Head 7/16-20 x 2.5"	83	04063-20	Key, 1/4 x 1/4 x 1"
32	04030-05	Lock Washer 7/16"			
33	04041-28	Flat Washer 7/16 x .469 x 1.75 x .25"			
34	04001-109	Bolt, Hex Head 1/4-20 x 1.375"			
35	04021-09	Nut, Elastic Stop 3/8-16			
36	04041-07	Flat Washer 3/8, .391 x .938 x .105"			
37	04063-20	Key, 1/4 x 1/4 x 1.00"			
38	461079	Idler Arm			
39	04001-46	Bolt, Hex Head 3/8-16 x 2.25"			
40	04019-04	Nut, Serr. Flg. 3/8-16			
41	48181	Pulley, PTO Idler			
42	04001-136	Bolt, Hex Head 3/8-16 x 1.5" Grade 8			
43	04043-04	Flat Washer 3/8" Grade 8			
44	481522	Spring			
45	48224	Bearing			
46	43503	Pivot, Idler - Short			
47	04001-31	Bolt, Hex Head 3/8-16 x 2.5"			
48	422714	Base, Idler Pivot			
49	04001-09	Bolt, Hex Head 5/16-18 x 1.00"			
50	461015	Idler Arm			
51	48198	Pulley, Pump Idler			
52	43277	Spacer			

* Common hardware which should be purchased locally. All bolts Grade 5 plated, all other fasteners zinc plated.

RADIATOR, COOLERS & ENGINE BRACKETS

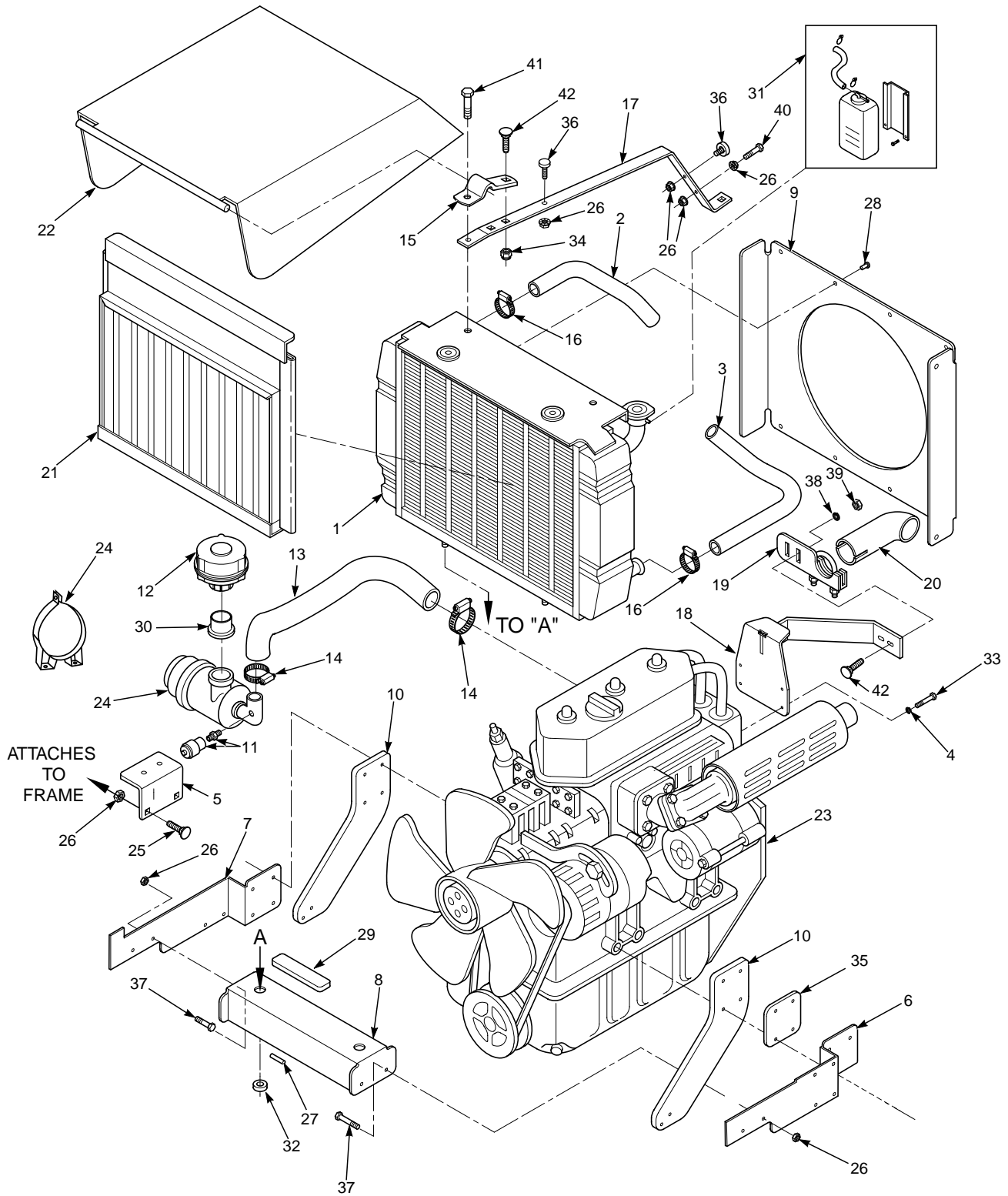

RADIATOR, COOLERS & ENGINE BRACKETS

Ref. No.	Part No.	Description
1	481810	Radiator
2	481742	Hose, Upper Radiator
3	481743	Hose, Lower Radiator
4	04030-03	Lockwasher, 5/16 (.317 x .586 x .078) Helical Spring
5	423628	Bracket, Air Cleaner
6	423539	Bracket, Engine Mounting LH
7	423540	Bracket, Engine Mounting RH
8	422702	Bracket, Radiator Mounting
9	422704	Shroud, Radiator
10	422696	Plate, Engine Mounting
11	481818	Indicator, Air Cleaner
12	481816	Pre-Cleaner, Engine Air (incl. item 30)
13	482522	Hose, Air Intake
14	48136-09	Clamp, Hose (2.25" Dia.)
15	422703	Hinge, Hood
16	48136-12	Clamp, Hose (1.50" Dia.)
17	422736	Bracket, Hood Support
18	451120	Bracket, Exhaust Support
19	451121	Clamp Weldment, Muffler (Clamp and Weldment)
	48633	Clamp, Muffler (Clamp Only)
20	481827	Elbow, Exhaust
21	451083	Screen, Debris
22	451082	Hood
23	481795	Engine, Briggs & Stratton 31 HP (Spec. # 580447-0116-E2) Not Available Through Scag, Contact Briggs & Stratton)
24	**	Air Cleaner Assembly w/ Mounting Band (Not Available Through Scag, Contact Briggs & Stratton)
25	04003-12	Bolt, Carr. 5/16-18 x .75"
26	04019-03	Nut, Serr. Flng 5/16-18
27	04069-02	Pin, Rue Cotter 1/2" dia.
28	04090-04	Rivet, Pop 1/8 x .294"
29	481817	Pad, Radiator
30	481924	Adaptor, Pre-Cleaner
31	**	Coolant Tank Assembly w/Hose (Not Available Through Scag, Contact Briggs & Stratton)
32	43508	Spacer, Radiator
33	04002-12	Bolt, Hex Head M8 x 20MM LG
34	04002-10	Nut, 5/16-18 Elastic Stop
35	422715	Engine Spacer
36	481284	Bumper, Rubber
37	04001-08	Bolt, Hex Head 5/16-18 x .75"
38	04040-15	Flatwasher, 5/16 (.375 x .875 x .083)
39	04021-10	Nut, 5/16-18 Elastic Stop
40	04001-11	Bolt, Hex Head 5/16-18 x 1.50"
41	04017-16	Bolt, Hex Head 5/16-18 x .75 Serrated Flange
42	04003-04	Bolt, Carrage 5/16-18 x 1.0"

* Common hardware which should be purchased locally. All bolts Grade 5 plated, all other fasteners zinc plated.

** Purchase through Briggs & Stratton.

BRAKE AND STEERING COMPONENTS

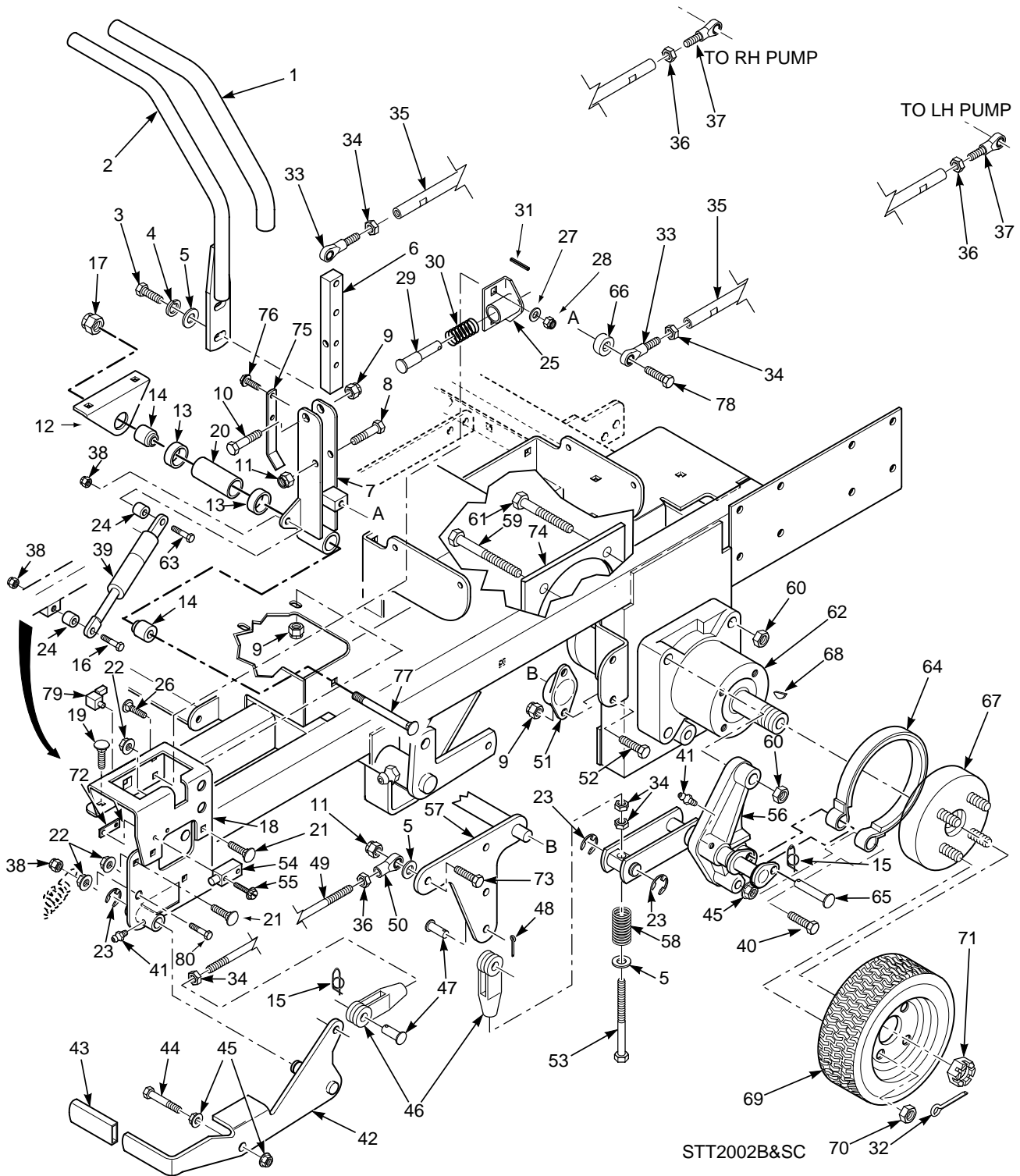

BRAKE AND STEERING COMPONENTS

Ref. Part No. No.	Description	Ref. Part No. No.	Description		
1	482340	Grip, Handle Bar	44	04001-22	Bolt, Hex Head 3/8-16 x 2-3/4"
2	461386	Handle Bar (Includes item 1)	45	04019-04	Nut, Hex Serrated Flange 3/8-16
3	04001-32	Bolt, Hex Head 3/8-16 x 1-1/4"	46	48343-04	Clevis, Traction Control
4	04030-04	Lockwasher, 3/8"	47	04064-02	Pin, Clevis 3/8-16 x 1-1/16"
5	04041-07	Flatwasher, 3/8" (.391 x .938 x .105)	48	04061-02	Pin, Cotter 3/32 x .75
6	422372	Bar, Control Lever	49	04004-34	Rod, Parking Brake
7	451483	Control Lever Weldment, LH	50	48544	Rod End, LH Thread
	451484	Control Lever Weldment, RH	51	48796	Bushing, Self Align
8	04001-17	Bolt, Hex Head 5/16-18 x 2"	52	04001-08	Bolt, Hex Head 5/16-18 x 3/4"
9	04021-10	Nut, Hex Elastic Stop 5/16-18	53	04001-147	Bolt, Hex Hd 3/8-24 x 5-1/4", 23/4" Thrd
10	04001-45	Bolt, Hex Head 3/8-16 x 2"	54	481637	Switch
11	04021-09	Nut, Hex Elastic Stop	55	04010-12	Screw, Hex SLTD WSHR Head #10 32 x 3/4"
12	423488	Mount, Control Linkage	56	461471	Brake Linkage, LH
13	48224	Ball Bearings, Neutral Return		461472	Brake Linkage, RH
14	43607	Spacer	57	45953	Bellcrank, Brake Actuator
15	04069-01	Pin, Rue Cotter 3/8 Dia.	58	48807	Spring
16	04001-13	Bolt, Hex Head, 5/16-18 x 2.75 Zinc.	59	04001-163	Bolt, Hex Head 1/2-13 x 3-3/4"
17	04021-13	Nut, Hex Elastic Stop 5/8-11	60	04021-19	Locknut, Hex 1/2-13 Center Lock
18	461601	Bracket, Control Lever LH	61	04001-52	Bolt, Hex Head 1/2-13 x 2-1/2"
	461602	Bracket, Control Lever RH	62	481787	Wheel Motor, Ross
19	04003-04	Bolt, Carriage 5/16-18 x 1"	63	04001-12	Bolt, Hex Head, 5/16-18 x 1.75, Zinc
20	43600	Spacer, Bearing	64	481601	Brake Band Assembly
21	04003-12	Bolt, Carriage 5/16-18 x 3/4"	65	04064-16	Pin, Clevis 3/8" Dia. x 1.93"
22	04019-03	Nut, Hex Serrated Flange 5/16-18	66	43063	Spacer
23	04050-01	Ring, Retaining 5/8" External "E"	67	461585	Wheel Hub/Brake Drum Assembly
24	43602	Spacer	68	04063-25	Key, Woodruff 5/16 x 1"
25	45918	Bracket, Neutral Return	69	481552	Wheel Assembly 23 x 10.5-12 (52" Only)
26	04003-02	Bolt, Carriage 1/4-20 x 3/4"		481659	Rim W/Valve Stem (52" Only)
27	04040-14	Flatwasher, 1/4" (.312 x .750 x .065)		481660	Tire, 23 x 10.5-12 (52" Only)
28	04021-08	Nut, Hex Elastic Stop 1/4-20		481850	Wheel Assembly 24 x 12-12 Turf Master
29	43477	Pin, Retaining Spring		481851	Rim W/Valve Stem
30	481389	Spring		481852	Tire, 24 x 12-12 Turf Master
31	04060-01	Roll Pin, Spring 5/32 x 3/4"	70	04028-02	Lug Nut, 1/2-20
32	04061-06	Pin, Cotter 9/16 x 1-1/2"	71	48680	Nut, Hex Castle
33	482586	Rod End, Male 3/8-24 RH Thread	72	422373	Threaded Plate
34	04020-25	Nut, 3/8-24 RH Thread	73	04001-20	Bolt, Hex Head 3/8-16 x 1-1/2"
35	481767	Tube, Control Link	74	423279	Plate Weldment, Motor Backing
36	04020-26	Nut, Hex 3/8-24 LH Thread	75	423491	Actuator Switch
37	482585	Rod End, Male 3/8-24 LH Thread	76	04017-16	Bolt, Hex Serrated Flange 5/16-18 x 3/4"
38	04021-10	Locknut, 5/16-18, Elastic Stop	77	04003-36	Bolt, Carriage 3/8-16 x 4-3/4"
39	482452	Gas Damper	78	04001-19	Bolt, Hex Head 3/8-16 x 1"
40	04001-31	Bolt, Hex Head 3/8-16 x 2-1/2"	79	481638	Switch
41	48114-04	Grease Fitting	80	04001-168	Bolt, Hex Head 3/8-16 x 1-1/4" Grade 8
42	461082	Lever, Parking Brake (Includes item 43)			
43	481548	Grip, Parking Brake			

* Common hardware which should be purchased locally. All bolts Grade 5 plated, all other fasteners zinc plated.

FUEL AND HYDRAULIC SYSTEM

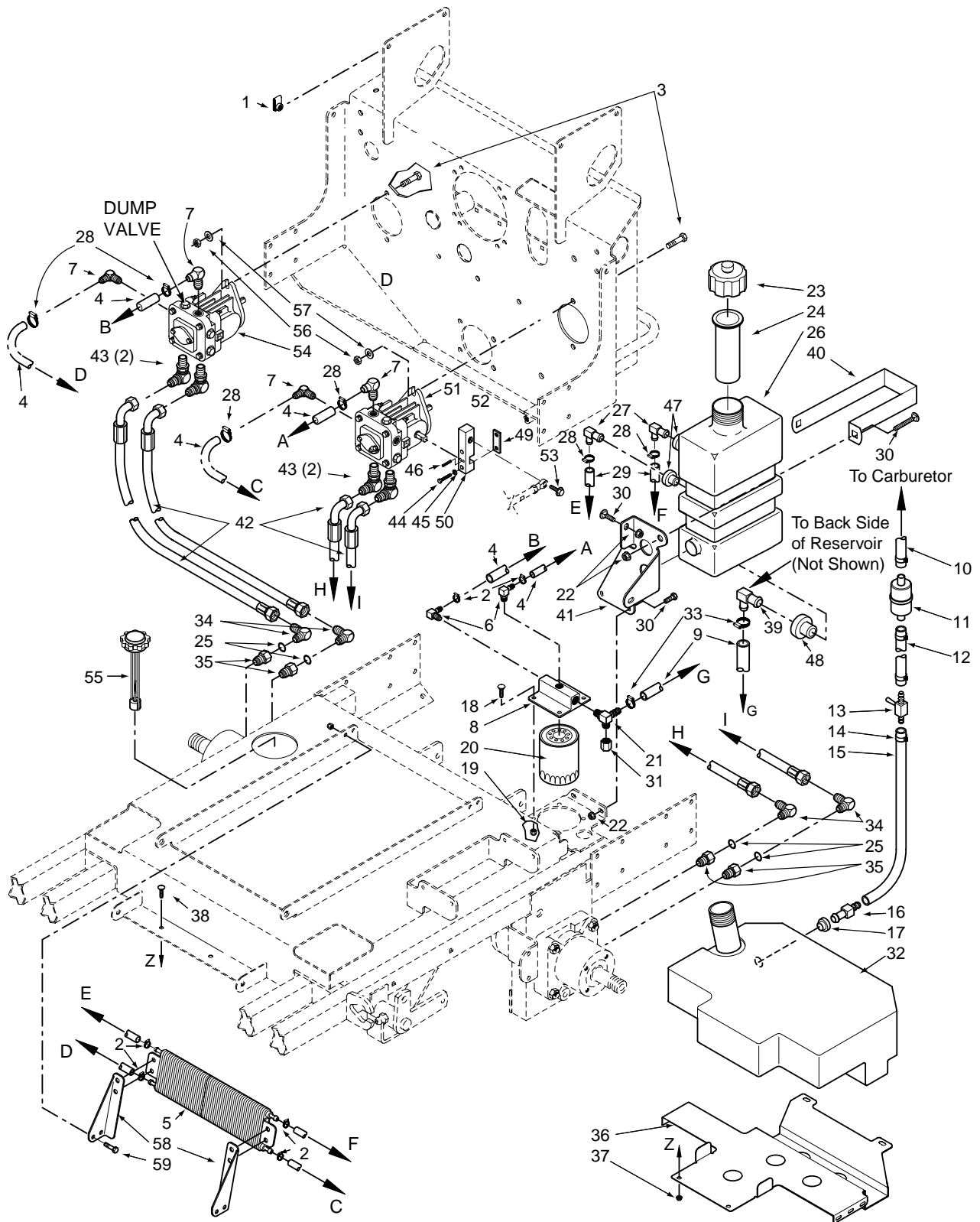

2002 STT-BSG F&HS.eps

FUEL AND HYDRAULIC SYSTEM

Ref. Part No. No.	Description	Ref. Part No. No.	Description
1	04110-01 U-Nut 1/4-20	36	423701 Support Bracket, Fuel Tank
2	48136-13 Hose Clamp, 0.69 dia.	37	04019-03 Nut, 5/16-18 Serrated Flange
3	04001-03 Bolt, Hex Head 1/4-20 x 2.0"	38	04003-02 Bolt, Carraige 1/4-20 x 3/4"
4	48811 Hose, 3/8" ID Pushlock - (order by inch)	39	482574 Elbow, 90 Degree
5	482505 Cooler, Oil	40	423513 Strap, Hydraulic Tank
6	482266-01 Elbow, 90 Degree - 9/16 O-ring x 3/8 Hose	41	423485 Support Bracket, Hydraulic Tank
7	482266-02 Elbow, 90 Degree - 3/4 O-ring x 3/8 Hose	42	482516 Hose Assembly, Pump
8	48471-02 Oil Filter Base	43	48350-05 Elbow, 90 Degree 7/8-14 Thread
9	482563 Hose Assembly, 1/2" ID (Tank to Filter Base)	44	04001-59 Bolt, Hex Head, 1/4-20 x 1-14"
10	48058 Fuel Hose to Carb., 1/4" ID (order by inch)	45	04030-02 Lockwasher, 1/4" Spring
11	** Fuel Filter	46	04060-06 Roll Pin, Spring 3/16 x 3/4"
12	48058 Fuel Hose, 1/4" ID. (order by inch)	47	482571 Bushing, .56 Dia.
13	48568 Valve, Shutoff	48	482573 Bushing, .78 Dia.
14	48059-02 Clamp, Fuel Hose 7/32 ID	49	422694 Clamp Plate, Pump Control
15	48058 Fuel Hose, 1/4" ID. (order by inch)	50	481793 Block, Pump Control
16	481602 Hose Fitting	51	481792 Pump, Left Hand, BDP-21L-305
17	48309 Bushing	52	04021-09 Nut, Hex, Elastic Stop 3/8-16
18	04001-09 Bolt, Hex Head 5/16-18 x1.0" Zinc	53	04001-32 Bolt, Hex Head, 3/8-16 x 1-1/4
19	04019-03 Nut, Serrated Flange 5/16-18	54	481819 Pump, Right Hand, BDP-21L-403
20	48758 Oil Filter	55	482497 Cap, Fuel Tank W/Guage
21	482483 Tee, 3/4 O-ring x JIC x 1/2" Hose	56	04021-09 Nut, Hex Elastic Stop 3/8-16
22	04021-08 Nut, Hex Elastic Stop 1/4-20	57	04043-04 Flatwasher, 3/8" (.391 x .938 x .105) Grade 8
23	481164 Cap, Hydraulic Tank	58	423524 Mounting Bracket - LH, Oil Cooler
24	481507 Insert, Filler Neck		423525 Mounting Bracket - RH, Oil Cooler
25	48603-02 O-Ring	59	04001-08 Bolt, Hex Head 5/16-18 x 3/4"
26	461451 Oil Reservoir Assembly (includes 24, 27, 39)		
27	482572 Elbow, 90 Degree, 9/16-18 JIC x 9/16 O-Ring		
28	48136-13 Hose Clamp, 0.69 dia.		
29	48811 Hose, 3/8" ID, Pushlock (order by inch)		
30	04010-10 Screw, Phillips Head, 1/4-20		
31	48571-02 Cap		
32	461445 Fuel Tank Assembly (includes items 23 & 24)		
33	48136-05 Clamp, Hose		
34	48350-05 Elbow, 90 Degree, 7/8-14 THD		
35	48938-02 Bushing, 7/8-14 JIC x 3/4-16 O-Ring		

* Common hardware which should be purchased locally. All bolts Grade 5 plated, all other fasteners zinc plated.

** Available through the individual engine manufacturer.

ELECTRICAL SYSTEM

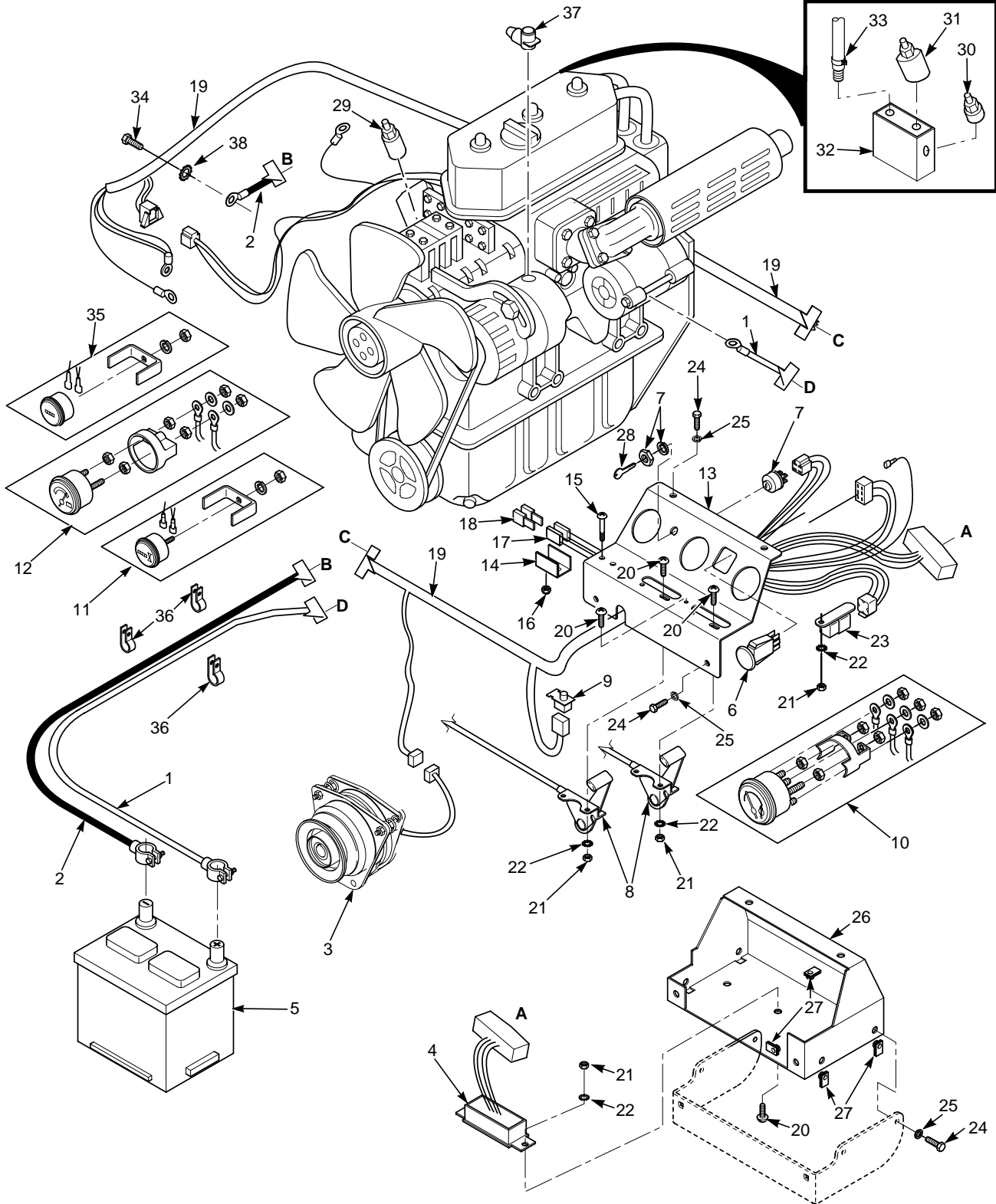

ELECTRICAL SYSTEM

Ref. Part No. No.	Description
1	481176-08 Cable, Positive Battery
2	481176-07 Cable, Negative Battery
3	461467 Clutch, Electric PTO
4	481808 Module, Interlock
5	482283 Battery (Not Avail. through Scag, Exide P/N 26R)
6	481687 Switch, PTO
7	48798 Switch, Key (Includes Nut and Lockwasher)
	48017-03 Nut, 5/8-32 Special
	48017-04 Lock Washer 5/8"
8	481806 Cable, Control (Throttle, Choke)
9	481638 Switch, Seat
10	481183 Gauge, Water Temperature
11	481805 Gauge, Oil Pressure
12	481184 Gauge, Volts
13	461393 Panel, Instrument Panel
14	42413 Bracket, Fuse Holder
15	04010-11 Screw, #10-32 x 1.5" Phillips
16	04021-01 Nut, #10-32 Elastic Stop
17	48297 Fuse Holder w/ 20 Amp Fuse
18	48298 Fuse, 20 Amp
19	482523 Harness, Wiring
20	04010-01 Screw, #10-32 x .5" Phillips
21	04020-01 Nut, Hex #10-32
22	04031-01 Lock Washer #10
23	48788 Relay
24	04001-01 Bolt, Hex Head 1/4-20 x .75"
25	04030-02 Lock Washer 1/4"
26	451081 Base, Instrument Panel
27	04110-01 U-Nut, 1/4-20
28	48017-02 Key & Ring Assembly
29	481791 Sender Unit, Water Temperature
30	481812 Switch, Low Oil Pressure
31	481811 Sender Unit, Oil Pressure
32	481813 Manifold, Oil
33	481919 Hose, Oil Pressure Sender
34	04002-17 Bolt, Hex Head M8-1.25 x 14
35	48023 Hour Meter
36	48030-09 Clamp, Cable .5" ID
	48030-11 Clamp, Cable .75" ID
37	481335 Boot, Positive Battery Terminal
38	04031-03 Washer, Star

* Common hardware which should be purchased locally. All bolts Grade 5 plated, all other fasteners zinc plated.

HYDRAULIC PUMP ASSEMBLY - BDP-21L

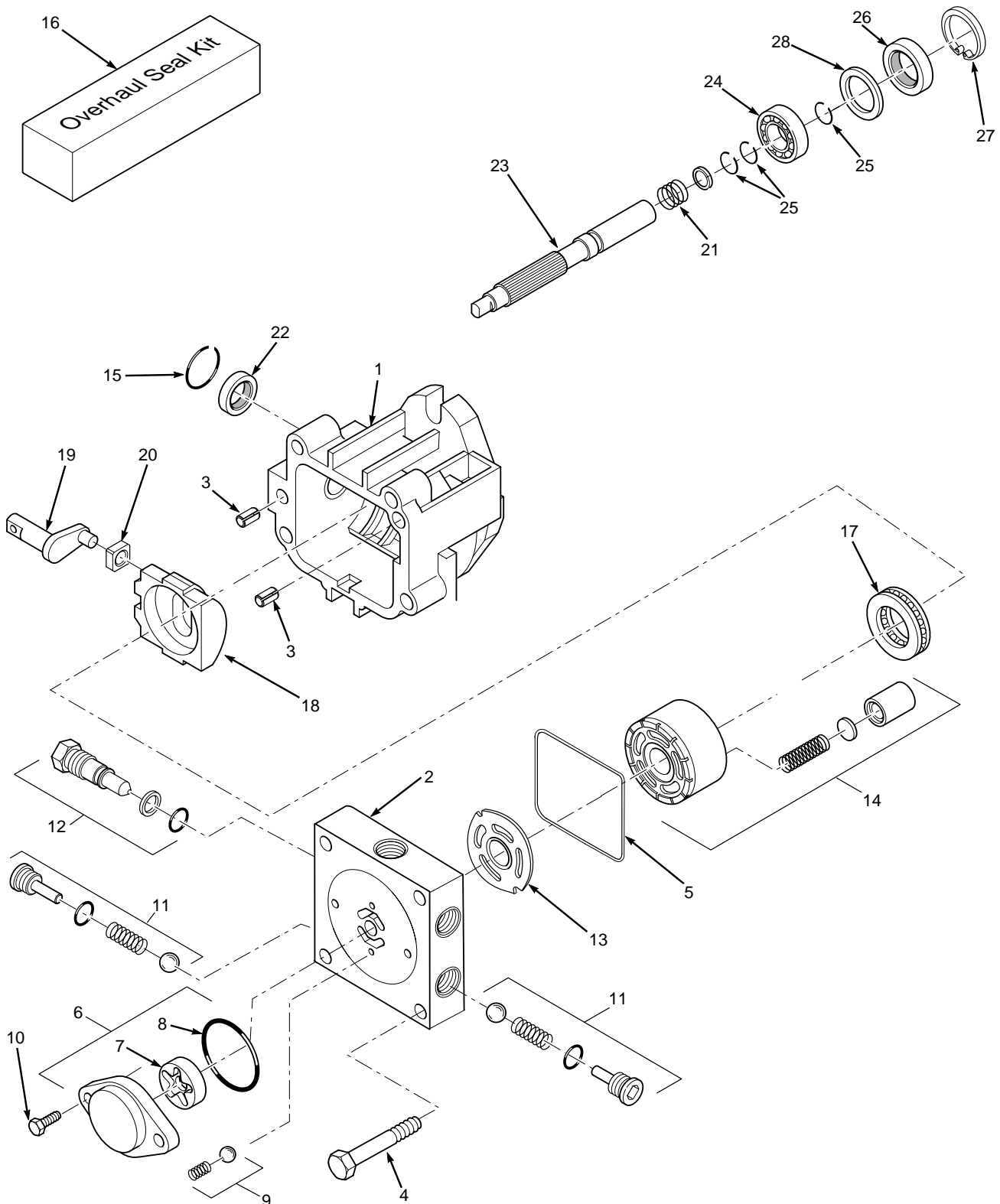

HYDRAULIC PUMP ASSEMBLY - BDP-21L

Ref. No.	Part No.	Description
1	HG 2510065	Housing Kit (Includes Housing, Journal Bearing)
2	HG 2510066	End Cap
3	HG 50641	Straight Headless Pin
4	HG 50633	Socket Head Screw
5	HG 50381	End Cap Gasket
6	HG 2510071	Charge Pump Kit (Includes Charge Cover, Gerotor Assy., O-Ring)
7	HG 50406	Gerotor Assembly
8	HG 9004100-1430	O-Ring
9	HG 70402	Charge Relief Valve Kit
10	HG 9007200-3116	Socket Head Screw
11	HG 2510027	Check Valve Kit (Includes Check Plug, Spring, O-Ring, Orifice Check Valve)
12	HG 2513030	Bypass Valve Kit (Includes Bypass Valve, O-Ring, Back-up Ring)
13	HG 50619	Valve Plate
14	HG 70080	Cylinder Block Kit
15	HG 50574	Trunion Seal Retaining Ring
16	HG 2510073	Overhaul Kit
17	HG 50552	Roller Thrust Bearing
18	HG 50203	Swash Plate
19	HG 2000014	Trunnion Arm
20	HG 2000015	Guide Slot
21	HG 2000025	Block Spring
22	HG 2000037	Lip Seal
23	HG 50601	Pump Shaft
24	HG 2000032	Ball Bearing
25	HG 2000038	Retaining Ring
26	HG 51092	Lip Seal
27	HG 2000038	Retaining Ring
28	HG 2000023	Spacer

WIRE HARNESS, STT - 31BSG PART NUMBER 482523

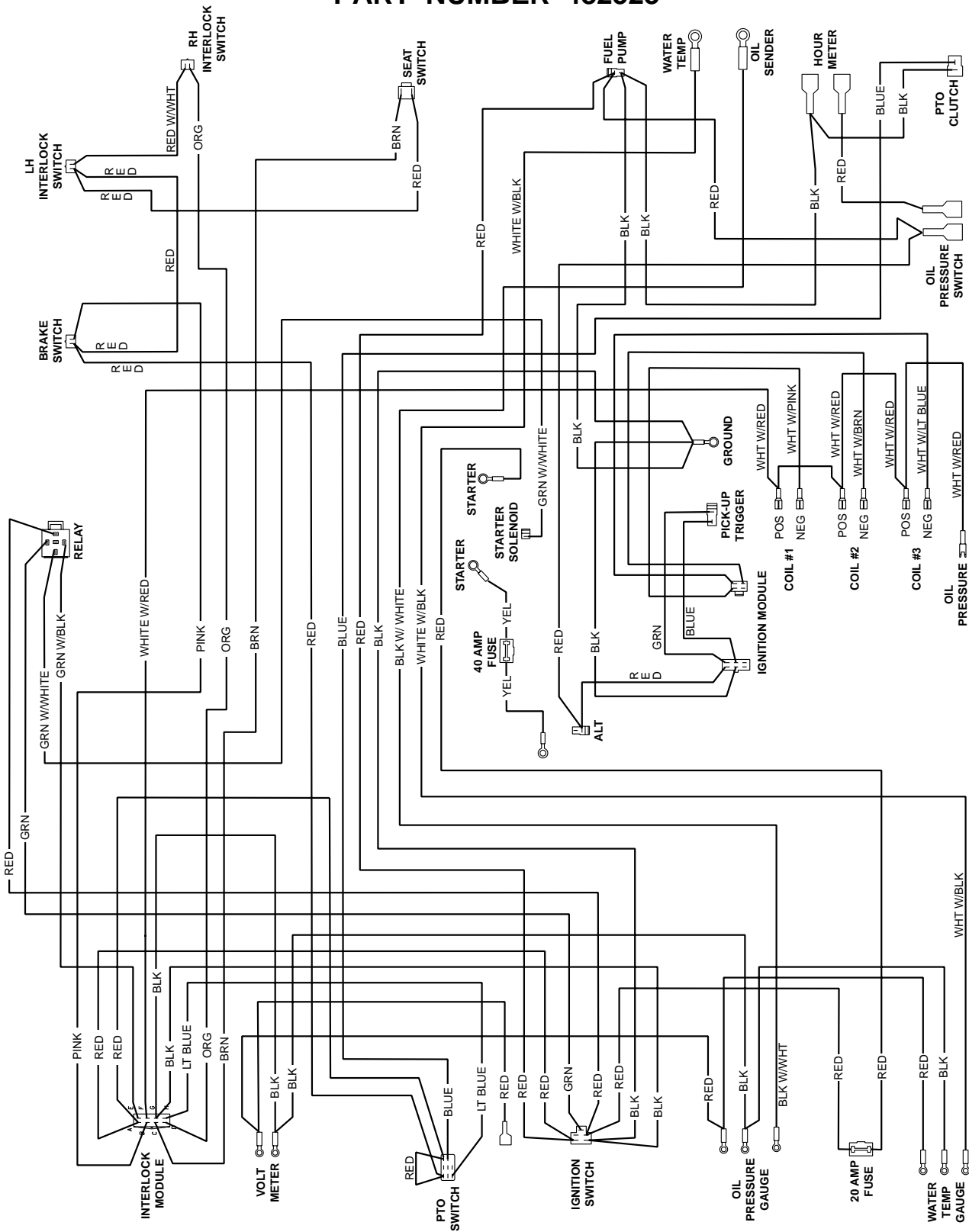

REPLACEMENT DECALS AND INFORMATION PLATES



482285

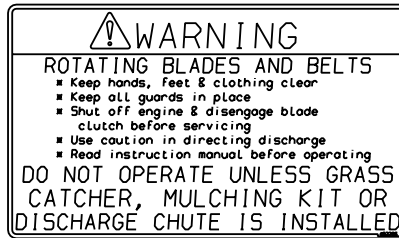

482286

72

481955 - 61A
481956 - 71A

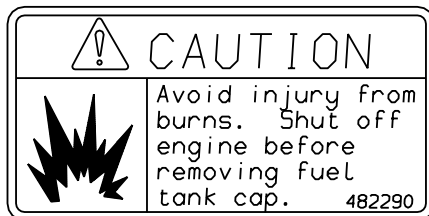

482290

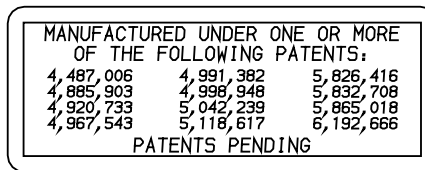

48656



48404



481568



481971



481039

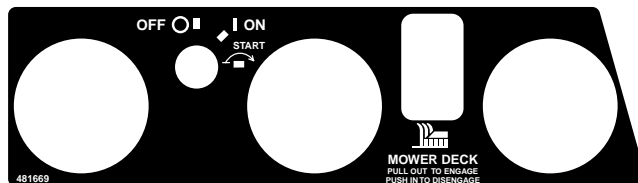

481669



482507

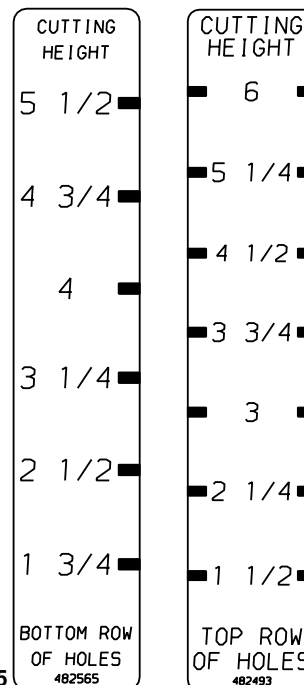

482565

482493

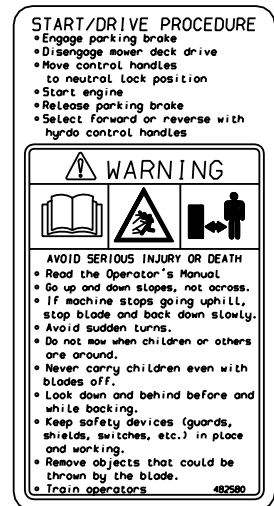

482580

REPLACEMENT DECALS AND INFORMATION PLATES



48825



48314

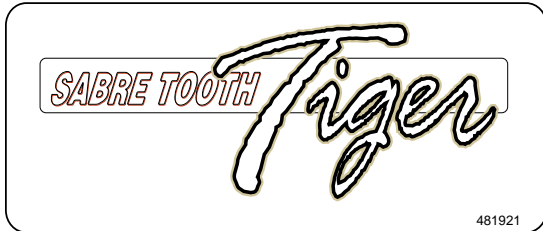

481921



481925

IMPORTANT ADJUSTMENT PROCEDURES
 READ OPERATOR'S MANUAL FOR MORE DETAILS
 Check tire pressure - (Drive tires-12 psi, Castor tires-25 psi)

NEUTRAL ADJUSTMENT
 Loosen jam nuts

Rotate turnbuckle
 With an operator in the seat, engine running, control levers in neutral and the parking brake disengaged - adjust control linkage. Loosen jam nuts. If wheel rotates forward, adjust turnbuckle CW. If wheel rotates rearward, adjust turnbuckle CCW. Adjust until drive wheel stops turning. Tighten jam nuts. Repeat for opposite side.

TRACKING ADJUSTMENT
 If the machine pulls to the right, adjust LH control linkage CCW to slow left wheel. If the machine pulls to the left, adjust RH control linkage CCW to slow right wheel. Readjust neutral if necessary.

FREE WHEEL OPERATION
 To move machine without running the engine, rotate both dump valves located at the LH side of the pumps CCW 1/2 turn to free-wheel positions. Return dump valves to original position to operate the mower. Tighten to 7-10 ft-lbs.

HYDRAULIC FLUID LEVEL
 Check hydraulic fluid level while fluid is cool. Fluid level should be 3" below top of filler neck. Fill with SAE 20W50 motor oil only.

IMPORTANT
 Do not overfill. Room for hot fluid expansion must be allowed or resulting expansion may cause leaks in the system.

IMPORTANT
 Grease lubricant: SAE 90W50 gear oil

IMPORTANT DRIVESHAFT MAINTENANCE
 Grease yokes 3-4 pumps Every 200 hours

Grease spline 8-10 pumps Every 50 hours

482710



481937

WARNING
 DO NOT OPERATE WITHOUT DISCHARGE CHUTE, MULCHING KIT, OR ENTIRE GRASS CATCHER INSTALLED

482165

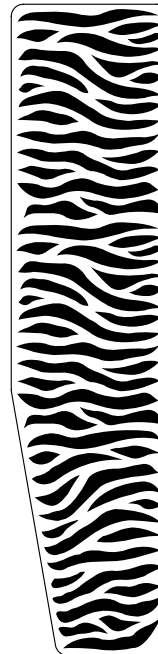

481664



481663

STT-31BSG Decals 2

LIMITED WARRANTY - COMMERCIAL EQUIPMENT

Any part of the Scag commercial mower manufactured by Scag Power Equipment and found, in the reasonable judgment of Scag, to be defective in materials or workmanship, will be repaired or replaced by an Authorized Scag Service Dealer without charge for parts and labor. This warranty is limited to the original purchaser and is not transferable. Proof of purchase will be required by the dealer to substantiate any warranty claims. All warranty work must be performed by an Authorized Scag Service Dealer.

This warranty is limited to the following specified periods from the date of the original retail purchase for defects in materials or workmanship:

- * Wear items including drive belts, blades, hydraulic hoses and tires are warranted for ninety (90) days.
- * Batteries are covered for ninety (90) days.
- * Frame and structural components including oil reservoir, fittings, and oil coolers are warranted for 2 years (Parts and labor 1st year; Parts only 2nd year).
- * Cutter decks are warranted against cracking for a period of three (3) years. (Parts and labor 1st year; Parts only 2nd and 3rd year) The repair or replacement of the cutter deck will be at the option of Scag Power Equipment. We reserve the right to request components for evaluation. This warranty does not cover any mower that has been subject to misuse, neglect, negligence, or accident, or that has been operated in any way contrary to the operating instructions as specified in the Operator's Manual.
- * Engines and electric starters are covered by the engine manufacturer's warranty period.
- * Major drive system components are warranted for two (2) years by Scag Power Equipment. (Parts and labor 1st year; Parts only 2nd year) (Two year warranty exclude fittings, hoses, drive belts). The repair or replacement of the hydraulic pump or hydraulic motor will be at the option of Scag Power Equipment. This warranty does not cover any mower that has been subject to misuse, neglect, negligence, or accident, or that has been operated in any way contrary to the operating instructions as specified in the Operator's Manual.
- * Electric clutches have a Limited Warranty for 2 year (Parts and labor 1st year; Parts only 2nd year).
- * Cutter Spindle Assemblies 46631 have a Limited Warranty for three years (Parts and labor 1st year; Parts only 2nd and 3rd year).
- * Any Scag product used for rental purposes is covered by a 90 day warranty.

The Scag mower, including any defective part must be returned to an Authorized Scag Service Dealer within the warranty period. The expense of delivering the mower to the dealer for warranty work and the expense of returning it to the owner after repair will be paid for by the owner. Scag's responsibility is limited to making the required repairs and no claim of breach of warranty shall be cause for cancellation or rescission of the contract of sale of any Scag mower.

This warranty does not cover any mower that has been subject to misuse, neglect, negligence, or accident, or that has been operated in any way contrary to the operating instructions as specified in the Operator's Manual. The warranty does not apply to any damage to the mower that is the result of improper maintenance, or to any mower or parts that have not been assembled or installed as specified in the Operator's Manual and Assembly Manual. The warranty does not cover any mower that has been altered or modified, changing performance or durability. In addition, the warranty does not extend to repairs made necessary by normal wear, or by the use of parts or accessories which, in the reasonable judgment of Scag, are either incompatible with the Scag mower or adversely affect its operation, performance or durability.

Scag Power Equipment reserves the right to change or improve the design of any mower without assuming any obligation to modify any mower previously manufactured. All other implied warranties are limited in duration to the two (2) year warranty period or ninety (90) days for mowers used for rental purpose. Accordingly, any such implied warranties including merchantability, fitness for a particular purpose, or otherwise, are disclaimed in their entirety after the expiration of the appropriate two year or ninety day warranty period. Scag's obligation under this warranty is strictly and exclusively limited to the repair or replacement of defective parts and Scag does not assume or authorize anyone to assume for them any other obligation. Some states do not allow limitations on how long an implied warranty lasts, so the above limitation may not apply to you.

Scag assumes no responsibility for incidental, consequential or other damages including, but not limited to, expense for gasoline, expense of delivering the mower to an Authorized Scag Service Dealer and expense of returning it to the owner, mechanic's travel time, telephone or telegram charges, rental of a like product during the time warranty repairs are being performed, travel, loss or damage to personal property, loss of revenue, loss of use of the mower, loss of time or inconvenience. Some states do not allow the exclusion or limitation of incidental or consequential damages, so the above limitation or exclusion may not apply to you. This warranty gives you specific legal rights, and you may also have other rights which vary from state to state.

© 2002
SCAG POWER EQUIPMENT
DIVISION OF METALCRAFT OF MAYVILLE, INC.

PART NO. 03121
PRINTED 7/02
PRINTED IN USA